

DEPA[®]

Air Operated Diaphragm Pumps

Operating and Installation Instructions Installation, Operation and Maintenance

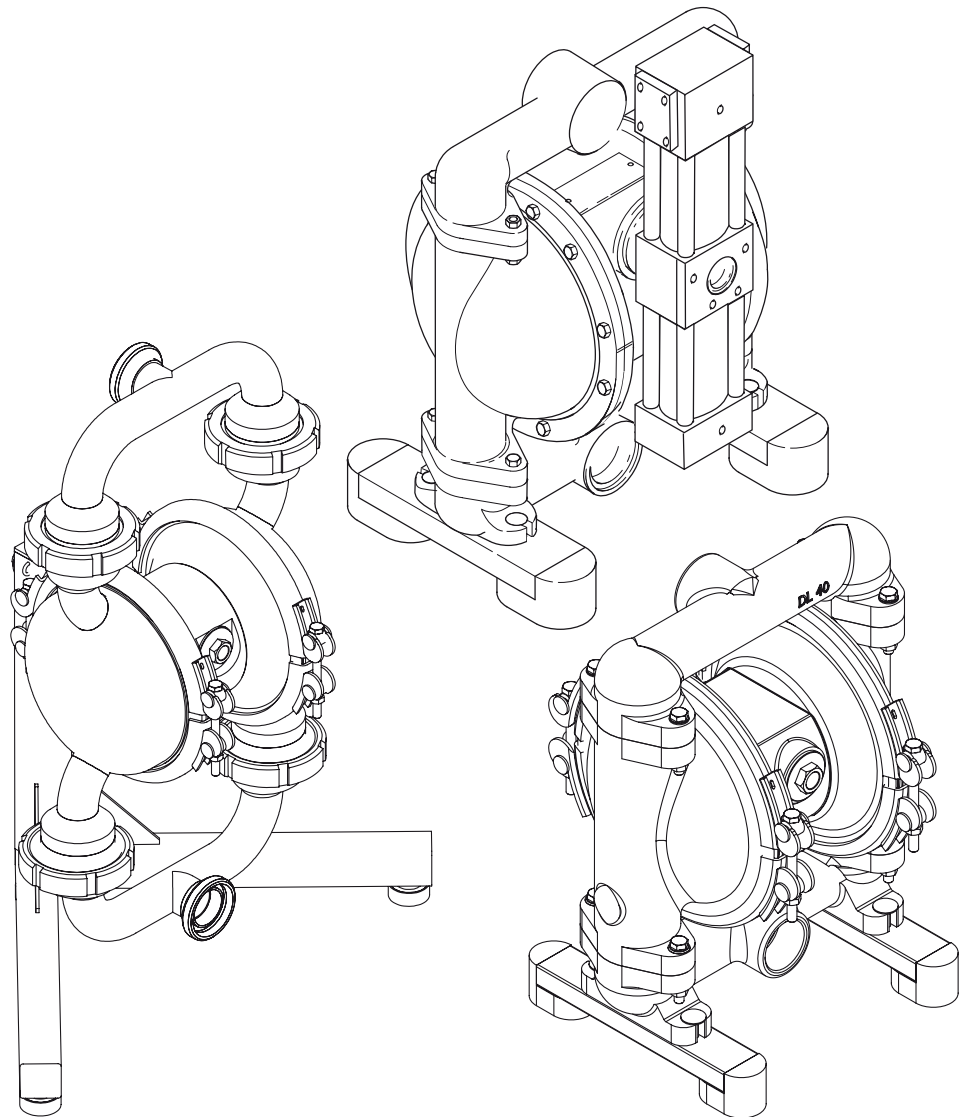

CRANE[®]



Declaration of Conformity

in compliance with the Machinery Directive 2006/42/EC

We hereby declare, that the pump units manufactured in series production

Designation: DEPA Air Operated Diaphragm Pumps
DEPA Active Pulsation Dampers

Series: DL, DH, DF, DZ, DP, DB DJ, PD, PH

Manufacturer: Crane Process Flow Technologies GmbH
Heerdter Lohweg 63-71
40549 Düsseldorf

Serial number: (see identification plate)

in the version delivered by us, is in compliance with the following applicable regulations:

EC Machinery Directive: 2006/42/EC

Harmonized standards: DIN EN 809
DIN EN 12100

Mr. Wolfgang Eitner is authorized to compile the technical documents.

Crane Process Flow Technologies GmbH
Heerdter Lohweg 63-71
40549 Düsseldorf

Place, date Düsseldorf, 29. December 2009

Signature of manufacturer: 

Information on signatory: H.-D. Ptak, Managing Director

**This is the translation of the original declaration of conformity
for DEPA Air Operated Diaphragm Pumps.**



ATEX



Declaration of Conformity

in accordance with directive 94/9/EC for equipment intended for use in potentially explosive atmospheres

The manufacturer Crane Process Flow Technologies GmbH,
Heerdter Lohweg 63-71, 40549 Düsseldorf,

declares that the pump units manufactured in series production

Designation: DEPA Air Operated Diaphragm Pumps and
DEPA Active Pulsation Dampers

Series: DL, DH, DF, DZ, DJ, DP, and PD, PH

Casing material: **Type A:** FA-, CA-, SA-, SF-, SL-, SU-, UE-
Type B: CX-, SX-, PL-, TL-, SS-, SFS

Diaphragm materials: DEPA E⁴® Compound diaphragm
PTFE with EPDM electrically conductive back diaphragm,
EPDM electrically conductive,
NBR electrically conductive, all diaphragms of size DL15

Accessories: **Type A:** Start-up valve, Q-valve, service unit,
clamping adapter, trolley
Type B: Needle valve, level control, trolley,
collecting pan, suction lance, high-performance
silencer, suction and pressure hose

Installed electrical components: Specific manufacturer's declarations of conformity are
supplied with all of the electrical units

in the version delivered by us, is in compliance with the following applicable regulations:

EC-directive: Directive 94/9/EC for equipment intended to be
used in potentially explosive atmospheres

Conformity assessment method: Pump and accessories type B
Equipment group I, category M2
Pump and accessories type A and B
Equipment group II, category 2GD

Harmonized standards: DIN EN 1127-1 (for pump and pulsation damper)
EN 13463-1 (for accessories)
EN 13463-5 (for accessories)

Mr. Wolfgang Eitner is authorized to compile the technical documents.
Crane Process Flow Technologies GmbH
Heerdter Lohweg 63-71
40549 Düsseldorf

Place / date: Düsseldorf, 29.12.2009

Signature of manufacturer:

Information on signatory: H.-D. Ptak, Managing Director



Declaration of Conformity

in accordance with directive 94/9/EC for equipment intended for use
in potentially explosive atmospheres

The manufacturer Crane Process Flow Technologies GmbH,
Heerdter Lohweg 63-71, 40549 Düsseldorf,

declares that the pump units manufactured in series production

Designation: DEPA Air Operated Diaphragm Pumps and DEPA Active Pulsation Dampers

Series:

M, P and L	
DL .. - CX	Grey cast iron / bronze
DL .. - SX	Stainless steel casting 316L / bronze
DL15-SFS	Stainless steel casting 316L / stainless steel
DL25/40/50-SFS	Stainless steel casting 316L / stainless steel
DL/DJ .. - SS	Stainless steel casting 316L / stainless steel
DL .. - SLV	Stainless steel 304 / stainless steel
DL .. - SUV	Stainless steel 316L / stainless steel
DL .. - UEV	Stainless steel 316L / stainless steel
DH .. - UEV	Stainless steel 316L / stainless steel
DL .. - PL	Polypropylene electrically conductive
DL/DH .. - TL/-FL	PTFE electrically conductive
PD.. - CX, SX, SL, SU, UE, PL, TL, SS	
PH.. - UE	

Design with

- diaphragm
- DEPA E4® compound diaphragm
- PTFE with EPDM electrically conductive back diaphragm
- EPDM electrically conductive
- NBR electrically conductive

Accessories:

Type A: Start-up valve, Q-valve, service unit, clamping adapter, trolley

Type B: Needle valve, level control, trolley, collecting pan, suction lance, high performance silencer, suction and pressure hose, ball lifter made of SS, PL and TL,

Installed electrical components: all electric units have their own declaration of conformity,
issued by the supplier

in the version delivered by us comply with the following applicable regulations:

EC-directive: Directive 94/9/EC for equipment for
intended use in potentially explosive atmospheres

Conformity assessment method:

Pump with / without accessories type B,
Pump with / without accessories type A and B
Equipment group II, category 2GD

Harmonized standards:

DIN EN 1127-1 (for pump and pulsation damper)
EN 13463-1 (for accessories)
EN 13463-5 (for accessories)

Mr. Wolfgang Eitner is authorized to compile the technical documents.
Crane Process Flow Technologies GmbH
Heerdter Lohweg 63-71
40549 Düsseldorf

Place / date: Düsseldorf, 29. December 2009

Signature of manufacturer:

Information on signatory: H.-D. Ptak, Managing Director



Declaration of Conformity

in accordance with directive 94/9/EC for equipment intended for use
in potentially explosive atmospheres

The manufacturer Crane Process Flow Technologies GmbH,
Heerdter Lohweg 63-71, 40549 Düsseldorf,

declares that the pump units manufactured in series production

Designation: DEPA Air Operated Diaphragm Pumps and DEPA Active Pulsation Dampers

Series: M, P and L

Type:

DL/DP .. –	FA cast aluminium / aluminium
DL .. –	CA grey cast iron / aluminium
DL .. –	SA cast stainless steel / aluminium
PD .. –	FS cast aluminium / stainless steel
PD .. –	CS grey cast iron / stainless steel
PD .. –	SS Stainless steel / stainless steel

Design with: Diaphragm
- DEPA E⁴® compound diaphragm
- PTFE with EPDM electrically conductive back diaphragm
- EPDM electrically conductive
- NBR electrically conductive

Accessories: Start-up valve, Q-valve, service unit, clamping adapter, trolley

Installed electrical components:

Specific manufacturer's declarations of conformity are supplied with all of the
electrical units
in the version delivered by us comply with the following applicable regulations:

EC-directive: Directive 94/9/EC for equipment for
intended use in potentially explosive atmospheres

Conformity assessment method:

Pump with / without accessories
Equipment group II, category 2GD

Harmonized standards:

DIN EN 1127-1 (for pump and pulsation damper)
EN 13463-1 (for accessories)
EN 13463-5 (for accessories)

Place / date: Düsseldorf, 29.12.2009

Signature of manufacturer:

Information on signatory:

H.-D. Ptak, Managing Director



Declaration of Conformity

in accordance with directive 94/9/EC for equipment intended for use
in potentially explosive atmospheres

The manufacturer Crane Process Flow Technologies GmbH
Heerdter Lohweg 63-71,
40549 Düsseldorf,

declares that the pump units manufactured in series production

Designation: DEPA Air Operated Diaphragm Pumps
Series: DL
Casing material: SS-
Diaphragm materials: PTFE with EPDM electrically conductive back diaphragm
EPDM electrically conductive, NBR electrically conductive
DEPA E⁴® compound diaphragm
Accessories: electrically conductive suction and pressure lines.
Installed electrical components: all electrical units have their own declaration of conformity
issued by the supplier
Supplementary operating manuals: DEPA air operated diaphragm pumps
BA-DL-D/12.09

in the design supplied by us comply with the following relevant regulations:

EC-directive: Directive 94/9/EC for equipment to be used in
potentially explosive atmospheres
Conformity assessment method: Pump and accessories:
Equipment group II, category 1G,
explosion group IIA (IIB) Tx
or II 1/2G IIA (IIB)Tx
EU prototype examination certificate : Federal Physical-Technical Office (PTB) in Braunschweig
ID-No. 0102:
PTB 04 ATEX 4014 X (4015 X)
Testing rules of the PTB in connection with
EN 1127-1, EN 50014 and EN13463-1
**Nominated body for
quality assurance:** TÜV Nord GmbH + Co. KG
Kurfürstenstr. 58, 45138 Essen,
ID-No. 0044
Place / date: Düsseldorf, 29.12.2009
Signature of manufacturer: 
Information on signatory: H.-D. Ptak, Managing Director



EG-Baumusterprüfbescheinigung

- (1) Geräte und Schutzsysteme zur bestimmungsgemäßen Verwendung in explosionsgefährdeten Bereichen - **Richtlinie 94/9/EG**



- (3) EG-Baumusterprüfbescheinigungsnummer

PTB 04 ATEX 4014 X

- (4) Gerät: Druckluftmembranpumpen Typ DL...-SS-...
- (5) Hersteller: Crane Process Flow Technologies GmbH
- (6) Anschrift: Heerdter Lohweg 63-71, D-40549 Düsseldorf
- (7) Die Bauart dieses Gerätes sowie die verschiedenen zulässigen Ausführungen sind in der Anlage zu dieser Baumusterprüfbescheinigung festgelegt.
- (8) Die Physikalisch-Technische Bundesanstalt bescheinigt als benannte Stelle Nr. 0102 nach Artikel 9 der Richtlinie des Rates der Europäischen Gemeinschaften vom 23. März 1994 (94/9/EG) die Erfüllung der grundlegenden Sicherheits- und Gesundheitsanforderungen für die Konzeption und den Bau von Geräten und Schutzsystemen zur bestimmungsgemäßen Verwendung in explosionsgefährdeten Bereichen gemäß Anhang II der Richtlinie.
Die Ergebnisse der Prüfung sind in dem vertraulichen Prüfbericht PTB Ex 04-44038 festgelegt.
- (9) Die grundlegenden Sicherheits- und Gesundheitsanforderungen werden erfüllt durch Übereinstimmung mit

Prüfregeln der PTB in Verbindung mit EN 1127-1, EN 50014 und EN 13463-1

- (10) Falls das Zeichen „X“ hinter der Bescheinigungsnummer steht, wird auf besondere Bedingungen für die sichere Anwendung des Gerätes in der Anlage zu dieser Bescheinigung hingewiesen.
- (11) Diese EG-Baumusterprüfbescheinigung bezieht sich nur auf Konzeption und Bau des festgelegten Gerätes gemäß Richtlinie 94/9/EG. Weitere Anforderungen dieser Richtlinie gelten für die Herstellung und das Inverkehrbringen dieses Gerätes.
- (12) Die Kennzeichnung des Gerätes muss die folgenden Angaben enthalten:



II 1 G IIA Tx oder II 1/2 G IIA Tx

Zertifizierungsstelle Explosionsschutz
Im Auftrag

Braunschweig, 2004-09-28

Dr. H. Bothe
Direktor und Professor



EG-Baumusterprüfbescheinigungen ohne Unterschrift und ohne Siegel haben keine Gültigkeit.
Diese EG-Baumusterprüfbescheinigung darf nur unverändert weiterverbreitet werden.
Auszüge oder Änderungen bedürfen der Genehmigung der Physikalisch-Technischen Bundesanstalt

Physikalisch-Technische Bundesanstalt
Braunschweig und Berlin



EG-Baumusterprüfbescheinigung

- (1) Geräte und Schutzsysteme zur bestimmungsgemäßen Verwendung
in explosionsgefährdeten Bereichen - **Richtlinie 94/9/EG**



- (3) EG-Baumusterprüfbescheinigungsnummer

PTB 04 ATEX 4015 X

- (4) Gerät: Druckluftmembranpumpen Typ DL...-SS-...
- (5) Hersteller: Crane Process Flow Technologies GmbH
- (6) Anschrift: Heerdter Lohweg 63-71, D-40549 Düsseldorf
- (7) Die Bauart dieses Gerätes sowie die verschiedenen zulässigen Ausführungen sind in der Anlage zu dieser Baumusterprüfbescheinigung festgelegt.
- (8) Die Physikalisch-Technische Bundesanstalt bescheinigt als benannte Stelle Nr. 0102 nach Artikel 9 der Richtlinie des Rates der Europäischen Gemeinschaften vom 23. März 1994 (94/9/EG) die Erfüllung der grundlegenden Sicherheits- und Gesundheitsanforderungen für die Konzeption und den Bau von Geräten und Schutzsystemen zur bestimmungsgemäßen Verwendung in explosionsgefährdeten Bereichen gemäß Anhang II der Richtlinie.
Die Ergebnisse der Prüfung sind in dem vertraulichen Prüfbericht PTB Ex 04-44039 festgelegt.
- (9) Die grundlegenden Sicherheits- und Gesundheitsanforderungen werden erfüllt durch Übereinstimmung mit

Prüfregeln der PTB in Verbindung mit EN 1127-1, EN 50014 und EN 13463-1

- (10) Falls das Zeichen "X" hinter der Bescheinigungsnummer steht, wird auf besondere Bedingungen für die sichere Anwendung des Gerätes in der Anlage zu dieser Bescheinigung hingewiesen.
- (11) Diese EG-Baumusterprüfbescheinigung bezieht sich nur auf Konzeption und Bau des festgelegten Gerätes gemäß Richtlinie 94/9/EG. Weitere Anforderungen dieser Richtlinie gelten für die Herstellung und das Inverkehrbringen dieses Gerätes.
- (12) Die Kennzeichnung des Gerätes muss die folgenden Angaben enthalten:



II 1 G IIB Tx oder II 1/2 G IIB Tx

Zertifizierungsstelle Explosionsschutz
Im Auftrag

Dr. H. Bothe
Direktor und Professor



Braunschweig, 2004-09-28

EG-Baumusterprüfbescheinigungen ohne Unterschrift und ohne Siegel haben keine Gültigkeit.
Diese EG-Baumusterprüfbescheinigung darf nur unverändert weiterverbreitet werden.
Auszüge oder Änderungen bedürfen der Genehmigung der Physikalisch-Technischen Bundesanstalt



Declaration of Conformity

in accordance with directive 94/9/EC for equipment intended for use
in potentially explosive atmospheres

The manufacturer Crane Process Flow Technologies GmbH,
Heerdter Lohweg 63-71,
40549 Düsseldorf,

declares that the pump units manufactured in series production

Designation: DEPA Air Operated Diaphragm Pumps
Series: DB
Casing material: XCA, XSA
without pressure booster
Diaphragm materials: DEPA E4® compound diaphragm
PTFE with EPDM electrically conductive back diaphragm
EPDM electrically conductive, NBR electrically conductive
Accessories: Start-up valve, service unit, clamping adapter, trolley
Installed electrical components: all electric units have their own declaration of conformity,
issued by the supplier

in the version delivered by us comply with the following applicable regulations:

EC-directive: Directive 94/9/EC for equipment to be used in
potentially explosive areas
Conformity assessment method: Pump and accessories:
Equipment group II; Category 1G,
Harmonized standards: DIN EN 1127-1 (for pump and pulsation damper)
EN 13463-1 (for accessories)
EN 13463-5 (for accessories)

Mr. Wolfgang Eitner is authorized to compile the technical documents.

Crane Process Flow Technologies GmbH
Heerdter Lohweg 63-71
40549 Düsseldorf
Place / date: Düsseldorf, 29. December 2009

Signature of manufacturer:

Information on signatory: H.-D. Ptak, Managing Director



Declaration of Conformity

In the sense of the regulation EC No. 1935/2004
concerning materials and objects that are intended to come
into contact with food

The manufacturer Crane Process Flow Technologies GmbH,
Heerdter Lohweg 63-71,
40549 Düsseldorf,

declares that the pump units manufactured in series production

Designation: DEPA – Air Operated Diaphragm Pumps and
DEPA Active Pulsation Dampers

Type: DL .. SLV PD .. SL
DL .. SUV PD .. SU
DL .. UEV PD .. UE
DH .. UEV PH .. UE

Size: DL/DH25, DL/DH40, DL/DH50, DL/DH80
PD/PH25, PD/PH40, PD/PH50, PD80

Diaphragms and ball valves made of: PTFE, EPDM - grey, or EPDM - black
DEPA E4® compound diaphragm

in the design delivered by us comply with the following regulations:

EC – Regulation: EC No. 1935/2004

Harmonized standards: DIN EN 1672 part 2 - 1997

**Further applied standards
and international guidelines:** 3A Sanitary Standard (44-03) and (20-22)
EHEDG Document No. 8, Report No. V4273
FDA 31 CFR 177.2600, "Rubber Articles"

Place, date: Düsseldorf, 29. December 2009

Signature of manufacturer:

Information on signatory: H.-D. Ptak, Managing Director

Table of contents

	Page
1.0. Introduction.....	13
1.1 Warranty	13
1.2 Transport, unpacking, storage	13
1.3 Principle of function	14
1.3.1 Functionality	15
1.4 Technical data.....	16
1.4.1 Dimensions, weights and temperatures	16
1.4.2 Control air	16
1.4.3 Air quality	16
1.4.4 Particle sizes, suction heads	16
2.0 Safety	17
2.1. General information	17
2.2 Danger sources	17
2.3 Permitted operators	17
2.4 Intended use	17
2.5 Unintended use	18
2.6 Conversions and alterations to the pump	18
2.7 Symbols	18
2.8 Maintenance and repair work	18
2.9 Personal protective outfit	19
2.10 Safety information for work on lines under pressure	19
2.11 Safety during storage	19
2.12 Noise emissions (2003/10/EC)	20
2.13 Use of pumps in potentially explosive areas	20
3.0 Installation.....	20
3.1 To be considered before commissioning	20
3.2 Design and arrangement of connecting lines	21
3.3 Placement and possible installations of the pump.....	21
3.4 Foundations.....	21
3.5 Connection of the air supply line	22
3.6 Connection of suction and pressure lines.....	22
3.7 Pump in suction operation	22
3.8 Pump in submerged operation	22
3.9 Pump with pre-pressure	23
3.10 Pump on drum	23
3.11 Equipotential bonding / earthing	23
3.12 Vibration distance	23
3.13 Routing of exhaust air.....	23
4.0. Operation.....	24
4.1. General.....	24

DEPA® Air Operated Diaphragm Pumps

	Page
4.2	Switching on the pump 24
4.3	Flow control 24
4.4	Switching off the pump 24
4.5	What to do in events of emergency 24
4.6	Remote operating indicator 24
4.7	Diaphragm monitoring - conductive 24
4.8	Diaphragm monitoring - capacitive 25
4.9	Cleaning of pumps for food applications (CIP-Clean in Place)..... 25
4.10	Complementary measures for “3-A Sanitary” requirements 25
4.10.1	Ball type feet..... 25
4.10.2	Leakage sensors and shut down in case of leaks 25
4.11	Pulsation damping 26
4.12	Downtimes..... 26
4.13	Taking out of service 26
4.14	Waste disposal after expiry of the expected service life 26
5.0	Maintenance..... 27
5.1	Inspection periods 27
5.2	Cleaning 27
5.3	Dismantling and assembling..... 28
5.3.1	Replacement of diaphragms, valve seats and valve balls..... 28
5.3.2	Replacement of elastomer components 29
5.3.3	Replacement of PTFE diaphragm 29
5.3.4	Replacement of the internal control valve 30
5.3.5	Replacement of the external Q-valve 31
5.4	Assembling the pump 31
5.4.1	Assembling new clamp bands 31
6.0	Troubleshooting 32
7.0	Active pulsation damper..... 34
7.1	Principle of function 34
7.2	Recommended installation schematic..... 34
7.3	Pulsation damper with diaphragm breakage monitoring 35
8.0	Spare parts..... 35
8.1	Spare parts storage 35
8.2	Ordering spare parts..... 35
9.0	Appendix “materials and pump coding”..... 36
9.1	Appendix “pump weights in kg” 37
9.2	Devices for use in potentially explosive areas..... 37
9.2.1	Example..... 37
9.2.2	Surface temperature..... 37
9.2.3	Devices for use in explosion endangered areas Supplement for type approved pumps of category 1 37
9.3	Classification of pump groups I and II 38
9.4	Tightening torques 39

1.0 Introduction

The following instructions solely refer to DEPA Air Operated Diaphragm Pumps. Since the pumps are used in combination with other assemblies, such as solenoid valves, sensors or pulsation dampers, the valid operating instructions for these components and the associated notes on safety must also be taken into account.

These instructions contain information on safety, installation, operation, maintenance, repair and environmental waste disposal of the DEPA Air Operated Diaphragm Pump. Thoroughly read these instructions before use and always follow the information contained therein.

Persons entrusted with the installation, operation, maintenance or repair of the pump must have read and understood these instructions, especially the chapter on “Health and Safety”. This applies in particular for those who are only occasionally involved in work on the pump, like cleaning or service personnel.

Each pump is subjected to stringent inspections and function tests before leaving the factory.

You should always bear in mind that a correct function, a long lifetime and optimal operational reliability of the pump mainly depend on

- correct installation
- correct commissioning
- and correctly performed maintenance and repair work.

Enquiries concerning service, spare parts or repairs should be addressed to the manufacturer or an authorized dealer.

Always provide the following information:

- Series
- Pump size
- Serial number of pump

This information is stamped on the identification plate on top of the pump.



Danger!

When returning pumps or pump parts to your supplier for repair or general overhaul, the delivery must be accompanied by certificates stating that pumps or pump parts are free of product and other aggressive or hazardous substances.

1.1 Warranty

The correct function of each DEPA Air Operated Diaphragm Pump is tested in the factory. The manufacturer or authorized dealer assumes warranty for the product as specified in the effective terms of sales and delivery. Faults resulting from the non-compliance with the aforementioned regulations and notes can only be rectified at the cost of the customer.

1.2 Transport, unpacking, storage

In order to avoid any problems you should

- check the delivered goods against the delivery note for completeness and correctness,.



Danger!

Consider the weight specified in chapter “Technical data” before attempting to lift the pump. Use only lifting gear of appropriate capacity. Do not step or stand under suspended loads.

DEPA® Air Operated Diaphragm Pumps

Fasten the lifting tackle so that the pump can be safely lifted.



Danger!
In order to avoid slipping of the sling the rope must be crossed over at the hook (Fig. 1).

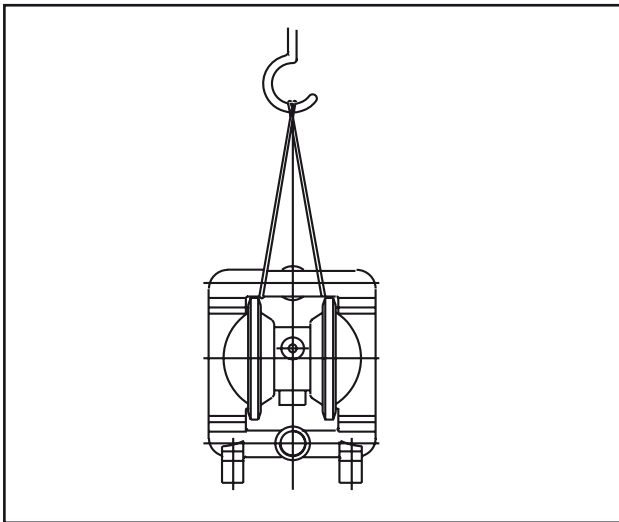

Fig. 1: Transport of pump

Be careful when unpacking the pump and proceed as follows:

- Check the packaging material for transport damage.
- Take the pump carefully out of the packaging material.
- Check the pump for visual damage.
- Remove the plugs from all pump ports.
- Check seals and fluid lines for damage.

The following points must be strictly observed when preparing the pump for storage:

- Store the pump in a dry place.

- Thoroughly clean used pumps before storage.
- Do not subject stored pumps to extreme temperature fluctuations.

1.3 Principle of function

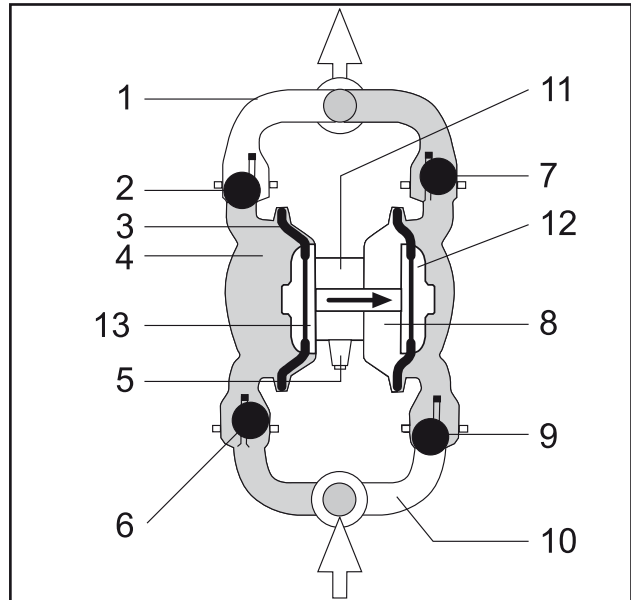

Fig. 2: Design of pump

- 1 Discharge manifold
- 2 Top valve ball
(closed during suction)
- 3 Diaphragm
- 4 Pump chamber
- 5 Silencer
- 6 Bottom valve ball
(opened. Medium flows into chamber)
- 7 Top valve ball
(open. Product is pressed out)
- 8 Air chamber
(the drive air displaces the medium via the diaphragm and at the same time pulls back the second diaphragm)
- 9 Bottom valve ball
(closed during delivery)
- 10 Suction socket
- 11 Air control unit
- 12 Outer piston
- 13 Inner piston

1.3.1 Functionality

DEPA Air Operated Diaphragm Pumps are oscillating positive displacement pumps with two pump chambers arranged opposite each other. Both of these are separated by a diaphragm each into an air and a fluid section.

Both diaphragms are linked by a piston rod, so that with every stroke product is displaced to the outside from the one pump chamber and product is drawn into the opposite pump chamber.

The four drawings opposite describe the sequence of a complete cycle consisting of a suction and pressure stroke, an empty and a filled pump chamber.

In order to explain the function the product to be pumped was highlighted in colour.

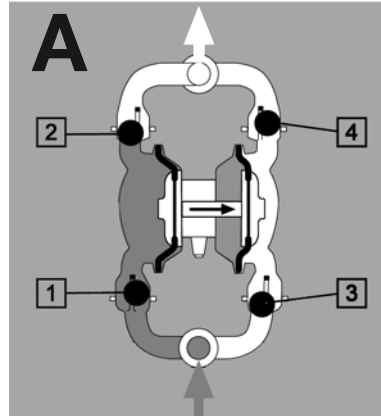

By filling the right hand air chamber (dark grey) the right hand diaphragm is pressed towards the outside. The piston rod thereby pulls the left hand diaphragm to initial position. Valve ball (1) is pulled out of its position, product (grey) flows into the left hand pump chamber. At the same time valve ball (2) is fixed in end position by the vacuum. The left hand pump chamber is thus completely filled with product (grey).

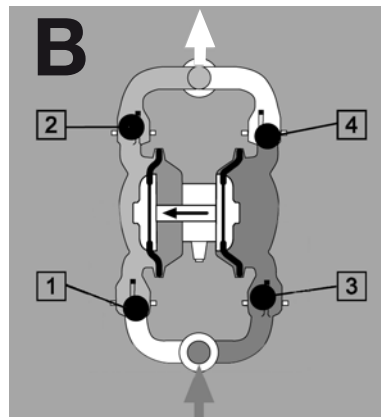

After switching of the control valve air flows into the left hand air chamber (dark grey), the right hand air chamber is vented. The suction process (see A) now takes place in the right hand pump chamber. Product (dark grey) is drawn in, product (light grey) in the left hand pump chamber is displaced to the outside. Valve ball (1) presses down, closes and valve ball (2) opens the flow path for product to the pressure outlet port.

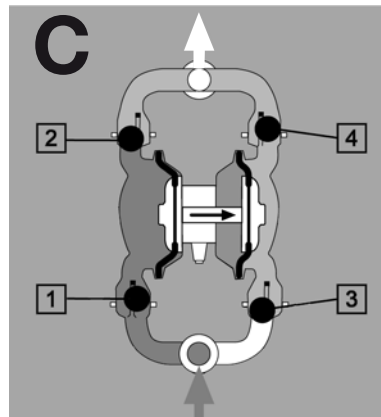

The suction process "A" is repeated with the only difference, that the right hand pump chamber is already filled with product (light grey). By switching of the control valve the right hand air chamber (dark grey) is filled, product (red) is drawn into the left hand pump chamber and the product from the right hand pump chamber (light grey) is displaced.

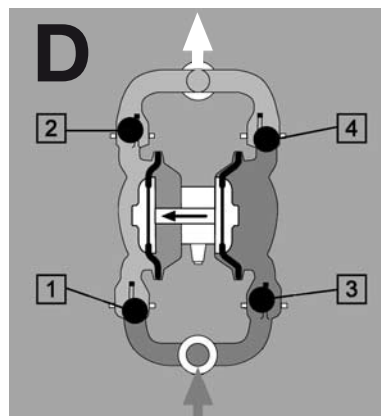

This sequence is repeated in reverse order as shown under C. The left hand air chamber (dark grey) fills up, vacuum draws product (dark grey) into the right hand pump chamber, while product (green) from the left hand pump chamber is displaced through the pressure port.

DEPA® Air Operated Diaphragm Pumps

1.4 Technical data

1.4.1 Dimensions, weights and temperatures

See corresponding data sheet.



Danger!
For correct selection of the lifting gear you should multiply the specified weight with factor 1.5.

Temperatures*	
DEPA E4® Compound diaphragm	-10° C – 130° C
NRS	-15° C – 70° C
EPDM (Nordel®)	-25° C – 90° C
NBR (Buna N®)	-15° C – 90° C
FKM (Viton®)	-5° C – 120° C
PTFE	-5° C – 130° C
PP	0° C – 60° C
PVDF	-12° C – 80° C
HytreI®	-25° C – 70° C

Tab. 1. Temperatures.

*Max. x. operating temperatures for diaphragms and plastic materials

In case of short-term exceeding the max. permanent operating temperature you should consult the manufacturer.

When using PP control blocks the max. ambient temperature is 60° C.



Warning! For operation with auxiliary heating you should observe the temperature limit.

1.4.2 Control air

- DL 15-80 max. 7 bar
- DB-pumps max. 7 bar
- DL..-SL, DL..-SU, DL..-UE, .DH..-UE with balls EPDM-grey max. 5 bar
- PD max. 7 bar

DEPA Air Operated Diaphragm Pumps are not subject to the pressure equipment directive acc. to article 1, para. 3.10, pressure equipment directive.

1.4.3 Air quality

Only air or inert gases of class 5 acc. to DIN ISO 8573-1 may be used as control air. (Class 5 corresponds with a max. particle size of 40µm; max. particle density 10mg/m³; max. pressure dew point +7°C; max. oil concentration 25 mg/m³).

Operating the pump with dry, non-lubricated and solids free compressed air prolongs the lifetime of the air control unit.



Warning!
Highly oil containing control air causes soiling of the control valve and swelling of the O-rings.

1.4.4 Particle sizes, suction heads

In order to ensure correct functioning of the pump the maximum product particle sizes listed in the following table must not be exceeded.

	Pump sizes				
	15	25	40	50	80
Particle size (mm)					
Standard	3,5	4	6	8	10
DL-PM	2,5	4	6	-	-
SL/SU/UE - Version	3,5	10	16	18	25
DH-PT/-TL	3,5	6,5	8	-	-
max. suction head [mWs]					
Standard dry *)	3,5	5,5	5,8	5,8	6
Standard filled with product	8,5	9	9	9	9
DL-PM	2,5	5,5	5,5	-	-
DH-PT/-TL dry *)	2	2	2	-	-
DH-PT/-TL filled with product	9	9	9	-	-

Tab. 2. Pump sizes.

*)Values are reduced when using PTFE diaphragms, seats and balls.

2.0 Safety

2.1 General information

These instructions were written for the operator and the maintenance and repair personnel. A well founded technical education and technical understanding is a major prerequisite. Persons lacking qualification have no permission to install, operate, service or repair the pump.

Installation, operation, maintenance and repair of the pump must in any case comply with the applicable national safety regulations and accident prevention instructions.

The following precautions must be applied before performing maintenance work.

If the product to be pumped is a hazardous or noxious substance, the system must be neutralized and vented. For this purpose the pump must strictly depressurized.

When cleaning the pump or its components you must make sure that all necessary precautions are in place.

Incorrectly installed, inattentively operated or insufficiently serviced pumps always are sources of potential dangers. The negligence of safety measures can cause severe personal injury or damage to the pump and connected units.

On pumps with protective covering and guards these must be properly assembled again before restarting.

In case of deficiencies adversely affecting the safety the pump must be shut down immediately and reliably secured against being switched on again. Only restart operation of the pump after all deficiencies have been rectified.

2.2 Danger sources

The pump works with pneumatic and hydraulic energies, which may be under high pressure.

Depending on its equipment, the pump may also work with electric energy.

Always relieve any pressure from the pump before starting work in the pneumatic or hydraulic system.

Always de-energize the pump before starting work in the electrical system.

Do not change any pressure settings to values higher than the ones specified in these instructions.

Safety facilities should not be removed or made ineffective.

2.3 Permitted operators

The pump must only be installed, operated, serviced and repaired by persons over 18 years of age. Persons under the influence of alcohol, medicine or drugs have no permission to install, operate, service or repair the pump.

2.4 Intended use

The air operated diaphragm pump is a working machine specially designed for the transport of aggressive, abrasive and viscous fluids. Any other use is unintended and causes the immediate loss of warranty.

2.5 Unintended use

The operating safety and reliability of the pump can only be assured if it is used for the purpose it is intended for. The limits mentioned in the corresponding technical data sheets must not be exceeded under any circumstances.

2.6 Conversions and alterations to the pump

Conversions and alterations to the pump are strictly prohibited. Safety installations must not be made ineffective or changed or used in a way contradicting their purpose.

2.7 Symbols

The following symbols are used to highlight dangers and particular operating situations.



Danger!
warns of possible bodily injury or danger to life, if the corresponding instructions are not observed.



Warning!
warns of possible damage to the equipment.



Attention!
warns of dangerous electrical voltage.



Note:
provides useful hints for optimal and economical use of the product.



Environment:
Gives tips on how to handle the product in an environmentally friendly way.



Danger of explosion:
provides special information on how to handle explosive product or operation in explosive environments.



Danger!
Warning against caustic substances.

2.8 Maintenance and repair work

Maintenance and repair work must solely be carried out by qualified and specially instructed persons. This applies particularly for work on electric, hydraulic and pneumatic facilities as well as for the handling of hazardous fluids and substances.

Pumps used for the transport of harmful product must be decontaminated.

Keep unauthorized persons away from the pump.

Repairs in mechanical and electrical systems must only be carried out by the respective expert personnel. The professional execution of this work must be examined and approved by a highly skilled and responsible "Inspector".

The system must be shut down before starting any repair or maintenance work.

Before starting maintenance or repair work you should always check whether the pump has been depressurized and de-energized.

Secure the pump reliably against being switched on again, for this reason:

- Lock switch or shut.off element and remove the key,
- Attach a warning label to the pump.

The operator is solely responsible for compliance with the accident prevention instructions valid at the place of use.

As a measure to avoid injury all maintenance, adjustment and repair work should only be carried out using permissible and appropriate tools and working aids.

Moveable parts must be locked in place before starting work. It must be assured that these parts will not start to move while work is in progress.

2.9 Personal protective outfit

You should always wear protective clothing suitable for the job, in particular for cleaning, maintenance and repair. Depending on the type of work you should wear the following protective outfit:

- protective overall
- goggles or face mask
- ear defenders
- hard hat
- safety boots
- gloves

If there is a risk that your face may come into contact with chemicals, splinters or dust, you should wear a full face protection.

Danger!



During operation the pump may develop extreme heat. You should therefore switch off the pump and let it cool down before touching it. On DB high pressure pumps the booster can reach a temperature of >70° C.

2.10 Safety information for work on lines under pressure

Danger!



Take care when handling dangerous (caustic, harmful) fluids.

Always relieve the pressure before starting work on pressure lines, for this purpose

- Close shut-off valves
- Vent lines



Danger!

Be careful when checking for leaks on pressurized lines. Fluids or air escaping under pressure can penetrate clothes and skin and cause severe injury.

Be careful when loosening or changing pressure lines; lines mixed up by mistake may reverse the function.

Moveable parts must be moved to a safe home or parking position.

Take care when handling dangerous (caustic, harmful) fluids.

Always wear your personal protective outfit.

If a dangerous substance comes into contact with skin or eyes or if vapours of such a substance have been inhaled, you should immediately consult a medical service.

Do not touch pump or pipelines during operation. Danger or burning!



Environment:

Catch and dispose of chemicals and dangerous substances environmentally.

Do not expose the pump to extreme and sudden temperature fluctuations. This may cause the pump to start leaking. Retighten clamp bands or mounting flanges!

2.11 Safety during storage

Always observe the applicable regulations when storing or handing out chemicals.

2.12 Noise emissions (2003/10/EC)

In a room with several pumps you may experience an extreme development of noise. Depending on the sound pressure level the following measures must therefore be applied:

- below 70 dB (A): No special measures required.
- above 70 dB (A): Persons who are permanently in the room must wear ear defenders.
- above 85 dB (A): Room with dangerous noise level! Each door must have a clearly noticeable warning sign to warn persons from entering the room without ear defenders.

Measured mean sound pressure level L_p [dB(A)] acc. to DIN EN 29614-2 (ISO 9614-2) in 1m distance with a pump head of 60 m, pump DL50-FA-NNN, control air 7 bar, medium water, 20 °C = 66.8 dB(A). With a different pump rating and pump size or other application related conditions the mean sound pressure level may deviate.

2.13 Use of pumps in potentially explosive areas

The chapter "Equipotential bonding/earthing" and "Vibration distance" must be observed when assembling the pumps.

Earthing of pump and pulsation damper by means of earthing screw or discharging hoses must take place before bringing the pump into the potentially explosive area.

All connected pipelines, components and hoses must be electrically conductive (bleeder resistance <1 Mega Ohm Meter; surface resistance <1 Giga Ohm).

When using the pump in zone 0 the exhaust air from the pump must be discharged from

the explosion endangered environment through an electrically conductive pipeline or an electrically conductive hose.

Pumps of sizes DL50 and DL80 must only be used with electrically conductive balls and seats, if they are to be used for pumping substances of explosion group IIA and IIB. In case of uncertainties you should consult the manufacturer mentioned in the declaration of conformity.

Chapter 9.2 shows pumps for use in explosion endangered environments.

Chapter 9.3 shows the categorization of device groups I and II.

3.0 Installation

3.1 To be observed before installation

- 1 The installation must only be carried out by persons who have the necessary skills for this work (see chapter 2 "Safety").
- 2 Before installation align the pump correctly and fasten it without any tension. Pipelines must be assembled in a way that the basic weight of the lines is not resting on the pump.
- 3 In order to avoid damage to the pump new installations should generally be checked for any debris (welding beads, pieces of wire, etc.) in tank and pipeline system.
- 4 Consider the arrangement of the pump with respect to suction and discharge heads.
- 5 The pump system must be designed according to the requirements of the application. Valves or spools must be installed as close as possible to pressure port.

This also applies for T-fittings with valve

for bypass control or pressure relief valves, pressure gauges, flow control valves and shut-off valves.

- 6 Thoroughly examine the alignment of the pump with the pipelines, in order to avoid strain and premature wear.
- 7 Check all pipelines for leaks. This applies in particular for the suction line, in order to avoid the intake of air.
- 8 If the fluid to be pumped contains solid particles bigger than specified in table 3, a filter must be installed. The filter must be of such a size, that the change in resistance at the pump inlet port is only minor. This filter must be permanently monitored and, if necessary, cleaned.
- 9 Fluids which change their viscosity must be permanently agitated, or the tank must be fitted with a temperature sensor. With increasing viscosity start the agitator and/or the heating. This is of special importance for intermittent operation!
- 10 Retighten the clamps bands on pump and pulsation dampener before initial start-up. The torques specified in section 9.4 must be observed.

3.2 Design and arrangement of connecting lines

By experience, the cross section of the pipelines must be designed to allow a flow velocity of 1 to 3 m/s in the pressure line and 0.5 to 1.5 m/s in the suction line (see table: sizes of pump connections).

The cross-section of the compressed air supply must not be smaller than the connection on the pump.

For simple removal of the pump a shut-off element each must be installed in the suction and pressure sides.

- The weight of the pipeline must be taken up before the pump.
- Elongation compensators must be installed to compensate any elongation of the pipes caused by temperature increase.



Note:
It is recommended to install flexible, shape and pressure resistant hoses or compensators at the suction and pressure ports of the pump. This will prevent the transfer of pulsation shocks into the pump.

3.3 Placement and possible installations of the pump

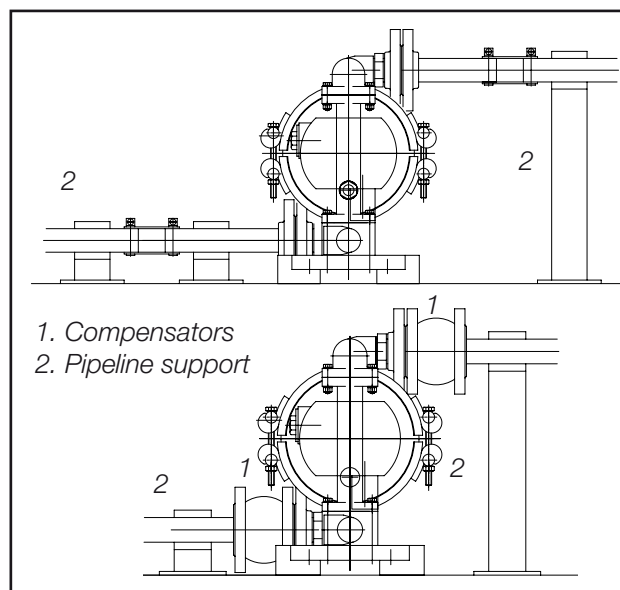

Fig. 3: Installation proposal for diaphragm pump

3.4 Foundations

Special foundations are not required. Each pump can be secured to the ground with dowels if appropriate.

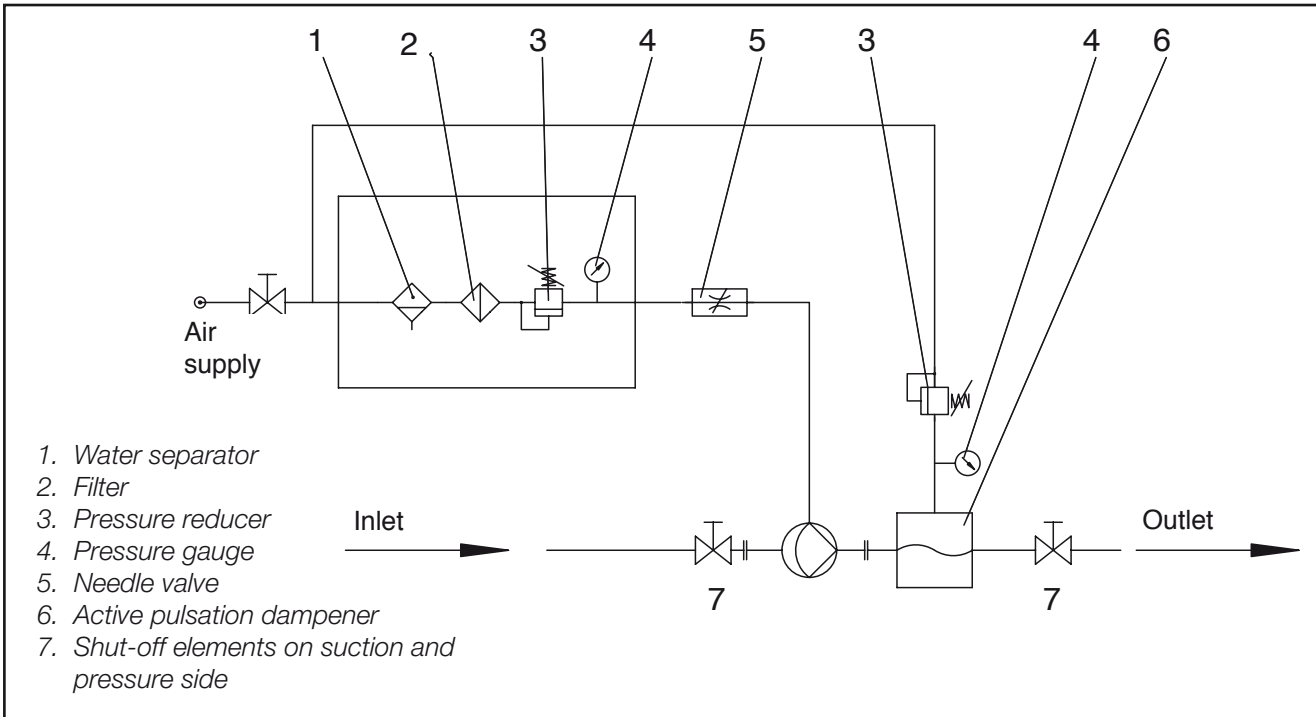

Fig. 4: Example of a pump installation

3.5 Connection of air supply line

We recommend to supply the air through a hose to the pump. Using moisturized compressed air requires the installation of a service unit with water separator. This control equipment can additionally be used to regulate the flow capacity of the pump. The diaphragm must not be subjected to shock loads. For this reason we recommend the installation of a spool, diaphragm or needle valve as shut-off element.



Warning!
Do not use a ball valve as shut-off element.



Note:
Especially for plastic pumps or pumps with PTFE diaphragms it is highly recommended to install a slow start valve in the supply line to the pump. This valve protects both the diaphragm and housing parts against suddenly occurring pressure shocks.

3.6 Connection of suction and pressure lines

Suction and pressure lines must be installed in a way that no additional loads are applied to the pump ports.

Always pay attention to the specified tightening torques for the fastening screws when assembling suction and pressure lines. After assembly check the system for leaks.

3.7 Pump in suction operation

DEPA Air Operated Diaphragm Pumps are dry self-priming. Depending on the pump design a suction head of max. 9 m Wc can be reached, when the suction line is filled (table 3).

3.8 Pump in submerged operation

The DEPA Air Operated Diaphragm Pumps are suitable for submerged operation. However, it must be assured that the surrounding fluid will not attack the pump.

When installing the pump make sure that the air discharge muffler has been removed and

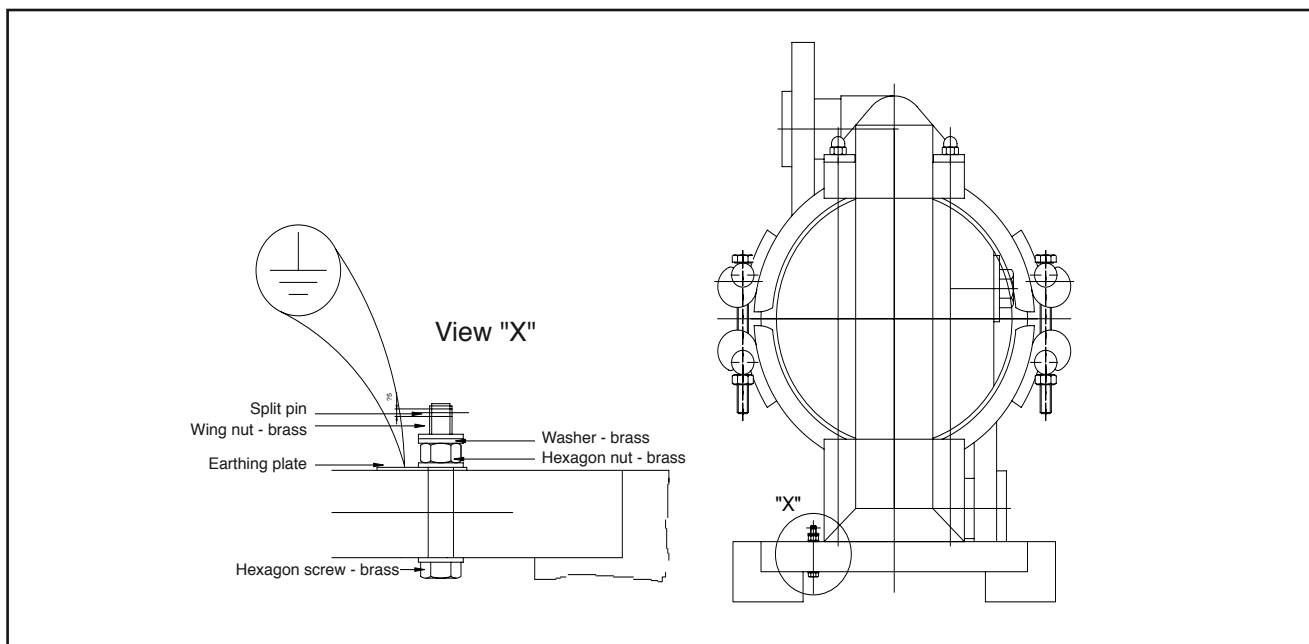

Fig. 5: Earthing screw

the exhaust air is discharged from the fluid through a hose.

Not for DB high pressure pumps

3.9 Pump with pre-pressure

Avoid excessive feed on the suction side. This causes irregular running of the pump with extreme noise. The results are limited power and reduced lifetime of the pump. The maximum pre-pressure on the suction side must not exceed 0.7 bar.

3.10 Pump on drum

DEPA pumps of type DF can be directly mounted on drums or containers. For simple emptying mount the pump with an adapter on the container. Complete emptying of the container requires the use of a suction pipe with adapted length.

3.11 Equipotential bonding / earthing

In principle, pumps and accessories must be earthed or provided with equipotential bonding if there is the possibility of product specific electro-static charging and when used in potentially explosive areas. Pumps

and pulsation dampers with ATEX-approval are therefore fitted with an earthing screw (Fig. 5).

3.12 Vibration distance

When installing the pump ensure a sufficient distance (DL15 to DL40 of at least 5 cm; DL50 and DL80 of at least 10 cm) between pump and other components, except the connections.

3.13 Routing of exhaust air

The muffler permanently discharges relieved compressed air. This air can whirl up dust and thus generate an explosive atmosphere.

For pumps used in potentially explosive areas of category 1 discharging the waste air out of zone 0 is mandatory.

4.0 Operation

4.1 General

After correct connection of suction and pressure line as well as the compressed air supply the pump is ready for operation.



Warning!

Make sure that the diaphragm is not subjected to a pressure difference of more than 2 bar.

Do not expose the pump to sudden temperature fluctuations. This may cause the pump to start leaking.



Danger!

Do not touch pump or pipeline. Danger or burning! Always wear your personal protective outfit when handling chemicals.



Environment:

Observe the applicable regulations for storage and hand-out of chemicals.

Dispose of chemicals according to legal regulations.

4.2 Switching on the pump

Warning!

The empty pump must never be immediately subjected to high pressure.



For automatic switching of the pump by means of a solenoid valve we recommend the upstream installation of a slow start valve.

The pump will start to deliver immediately after opening the air flow.

4.3 Flow control

The pump flow can be regulated via the fed air pressure and the air quantity. We recommend an air flow dependent regulation, in order to rule out fluctuations in pumping pressure. The air pressure must in this case be considerably higher than the pumping pressure. It is recommended to run the pump with a stroke frequency as low as possible, in order to save wear items, e.g. diaphragms, ball valves and air control valve and to protect the environment.

4.4 Switching off the pump

To shut-off the pump reduce the air flow to the pump by means of the valve. The pump will stop immediately.



Warning!

If the pumped product is of aggressive nature the pump must be thoroughly flushed or cleaned after use.

Observe the notes on cleaning.

4.5 What to do in events of emergency

In an event of emergency the pump must be switched off immediately.

4.6 Remote operation indicator

Operation of the pump can be electronically monitored by means of a remote operation indicator.

4.7 Diaphragm monitoring - conductive

With a defective diaphragm product will enter into the air chamber, where it is detected by the integrated sensor. When pumping conductive product the conductivity measurement will measure a current flow between both electrodes.

The evaluation unit supplies the sensor with voltage and from a certain amperage (<1mA) it switches a relay, which in turn switches the pump off or triggers an alarm signal.



Note:
The product must have a minimum conductivity value of $>5\mu\text{S}$.

4.8 Diaphragm monitoring - capacitive

When pumping non-conductive product diaphragm monitoring requires the use of a capacitive sensor system.

4.9 Cleaning pumps for food applications (CIP = Clean In Place)

The pumps can be cleaned manually after dismantling or in place (CIP). Consult the pump supplier for special application related cleaning procedures.

Here an example for CIP-cleaning:

- To clean the inside, the pump must be flushed with cold water during operation.
- Flush with approx. 2.5% caustic soda solution at 70 - 80°C for approx. 20 - 30 minutes.
- Finally flush again with cold, clear water.



Warning!
During all CIP cleaning processes the DEPA® Air Operated Diaphragm Pump must be running. Otherwise the diaphragm may be excessively stretched and prematurely damaged.



Warning!
Reassemble clamp bands or mounting flanges after cleaning, retighten if necessary!

4.10 Complementary measures for “3-A Sanitary” requirements

4.10.1 Ball feet

For requirements acc. to “3-A Sanitary” rubber feet are only permitted if they are stuck to the floor. The delivery includes “3-A Sanitary” compatible feet with round contact face for subsequent installation. For this purpose the counter screws at the top of the foot holder must be loosened and the rubber feet with their holders must be unscrewed. Now the feet with the round contact face can be screwed in and fastened.

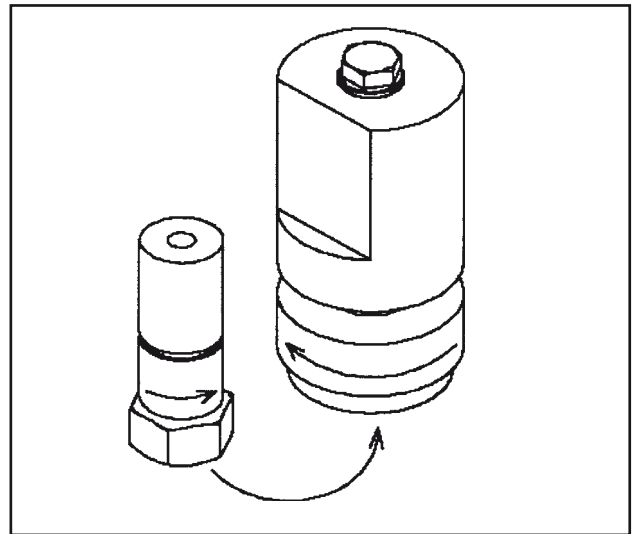

4.10.2 Leakage sensors and shut down in case of leaks

Due to the “3-A Sanitary” standard air operated diaphragm pumps are equipped with an inherently safe leakage monitoring system. In case of a leak the compressed air supply is interrupted. The electric connections can be taken from the wiring diagram on page 23 (Fig. 7).

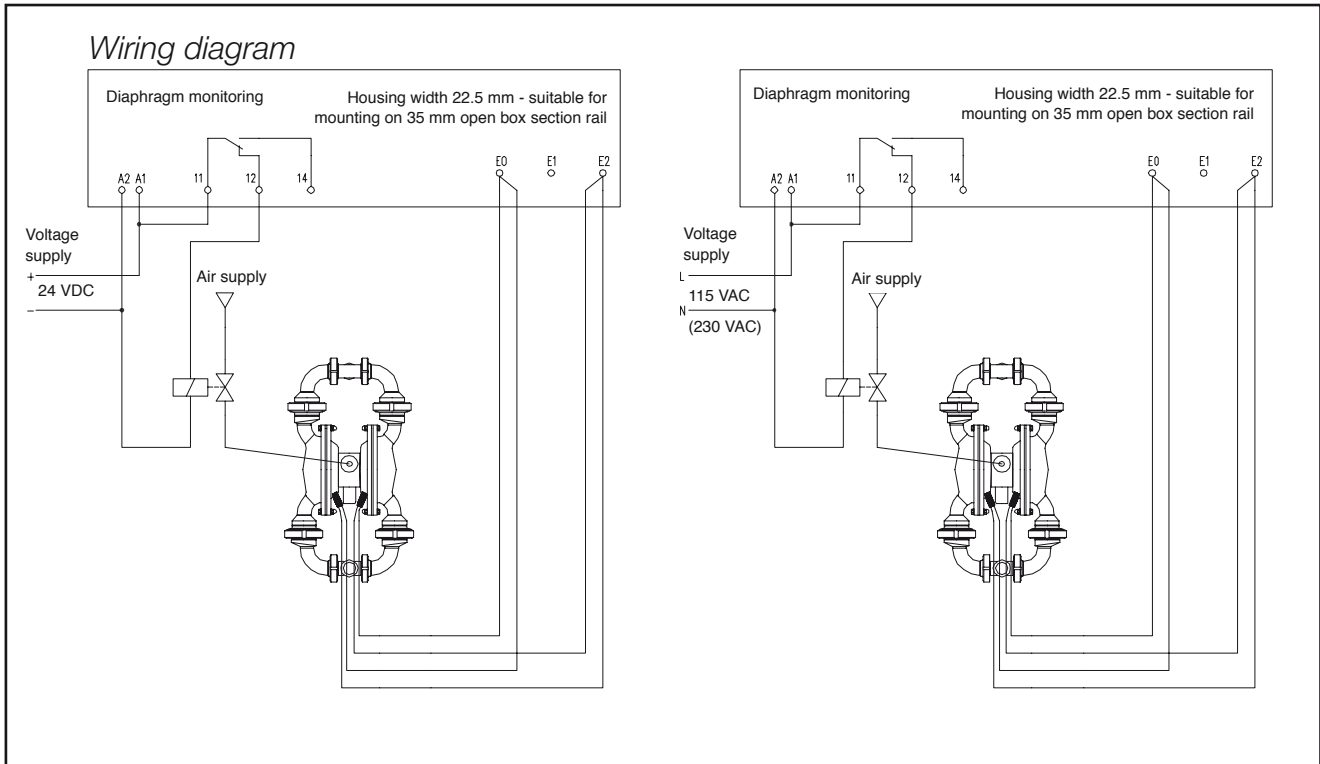

Fig. 7: Wiring diagram leakage sensors

4.11 Pulsation damping

Air operated diaphragm pumps are double-acting, oscillating pumps and thus generate a pulsating flow. For minimizing this pulsation we recommend the use of pulsation dampeners. There are various designs available, active and passive, made of metal or plastic, with and without diaphragms and in several different sizes. Depending on the prevailing pressure conditions they must be manually or automatically adjusted in-situ.

4.12 Downtimes

After pumping product with solids, chemicals or oils the pump chambers must be thoroughly flushed before shutting down. This prevents the settlement of solids or chemical attacks and thus the destruction of the diaphragms when restarting.

4.13 Taking out of service

The pump stops when cutting off the air supply. Since the valve balls in suction and pres-

sure sides act as non-return valves, the rising part of the pressure line will always remain filled with product. When disassembling the pump care must be taken, as the pump may still be filled with product. The pump itself can be partly emptied through the plugs on the sides of the pump (optional).

4.14 Waste disposal after expiry of the expected service life



The metal components used, such as aluminium, grey cast iron, high-grade steel and steel can be returned for recycling. Plastic parts cannot be reused and must be disposed of as refuse.

5.0 Maintenance

5.1 Inspection periods

- Visual inspection every week.
- Depending on type and/or duration of use disassembly and renewal of wear items every 4 weeks to 6 months.
- Since PTFE deforms under pressure, the following pumps must be checked for leakage at regular intervals and the screw connections must be retightened as necessary:

Type	Inspections interval	Srew joint
PM with PTFE Valve seats	weekly	Annchor rod, Clamp band
DL-PT/-TL	monthly	Annchor rod, Clamp band
DH-PT/-TL	monthly	Socket / Pump chamber

Tightening torques see 9.4

5.2 Cleaning



Danger!
Always observe the notes on safety in chapter 2 "Safety".

Check all lines and fittings regularly for leaks and externally visible damage! Repair any damage immediately!



Danger!
If the pump is used for aggressive, caustic or toxic product, the pump must generally be flushed with a neutral agent before opening the pump housing.

Always wear protective clothing when working with solvents and/or cleansing agents.

The following is generally valid:

The pump should preferably be cleaned mechanically instead of using chemical means. When using chemical cleansers, the

compatibility with the pumped product must be assured..

5.3 Dismantling and assembling



Danger! Before disassembly the pump must be disconnected from the compressed air supply and removed from the system.

General

In case of damage on the pump you may perform the following work to replace the damaged assemblies and parts. Please bear in mind that the manufacturer or the authorized dealer will only accept possible warranty claims if the pump is returned without being opened.



Note: For repairs use only genuine DEPA spare parts, as otherwise the warranty will become null and void.

5.3.1 Replacement of diaphragms, valve seats and valve balls

Depending on the application, air operated diaphragm pumps can be delivered with various elastomer materials. The following materials are available:

Hytrel®		no identification
NRS		marked yellow
NBR	(Buna N®)	marked red
EPDM	(Nordel®)	marked blue
EPDM-grey		no identifying colour
FKM	(Viton®)	no identifying colour
PTFE	(Polytetrafluorethylene)	no identification
DEPA E4® Compound diaphragm		no identification

The specified colour marks only apply for valve balls and valve seats. The diaphragms are marked by corresponding characters.

DEPA® Air Operated Diaphragm Pumps

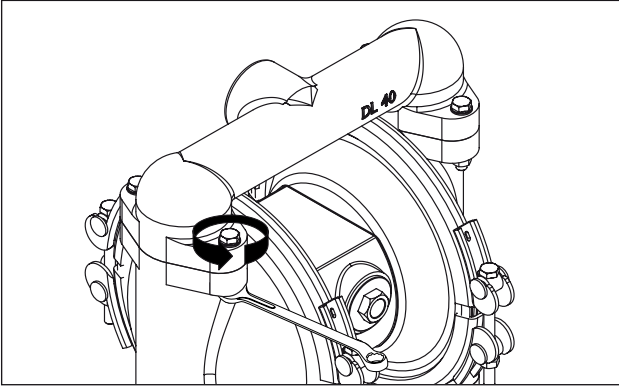

Fig. 8: Removing suction and pressure ports.

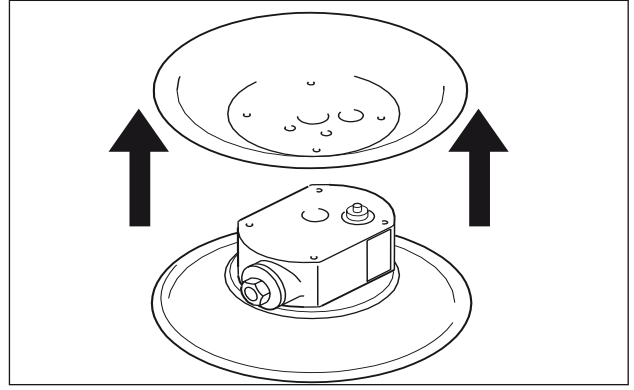

Fig. 12: Disassembling the air chambers

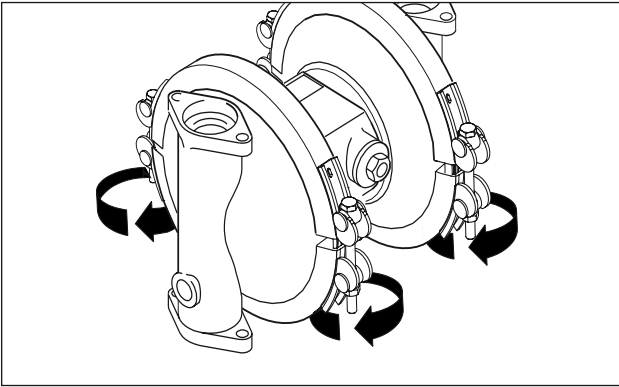

Fig. 9: Opening the clamp bands.

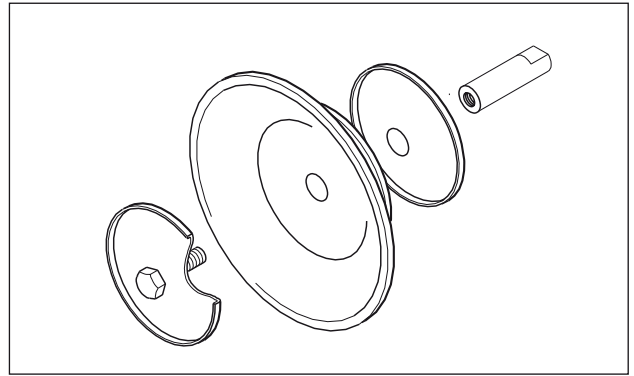

Fig. 13: Assembly of standard diaphragm with inner and outer plate

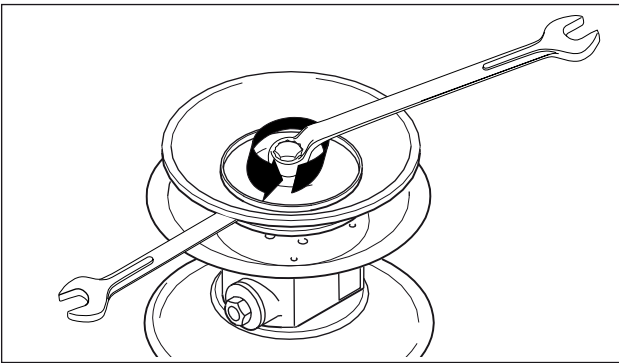

Fig. 10: Loosen the diaphragm plate. (not used for DEPA E4® compound diaphragm.)

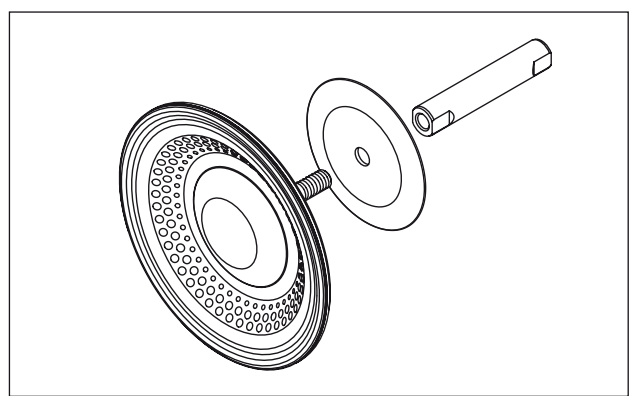

Fig. 14: Assembly DEPA E4® compound diaphragm

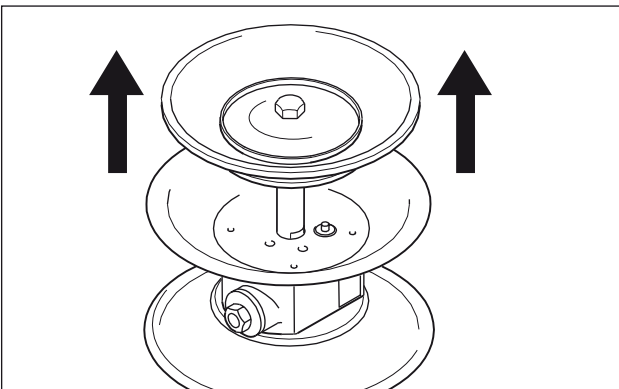

Fig. 11: Pulling out the piston rod.

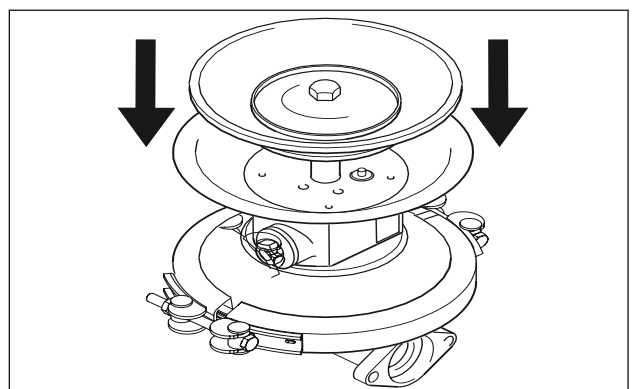

Fig. 15: Assembly of second pump chamber

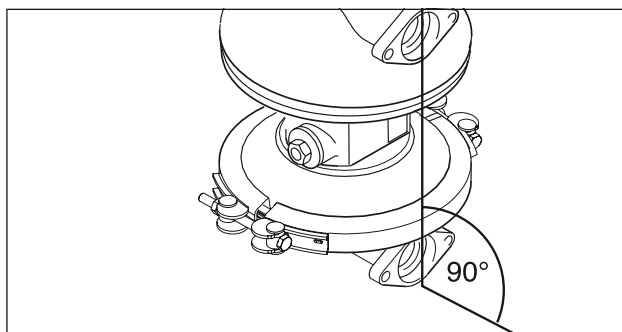

Fig. 16: Alignment of pump chambers

Before installing a new set of diaphragms, valve seats and valve balls make sure that the available material is suitable for the intended use (see compatibility list).

If the defective parts in the pump have not been damaged by normal mechanical wear, but show signs of chemical attack, you should use a different material.

5.3.2 Replacement of elastomer components

- Loosen the screws and disassemble pressure and suction sockets (Fig. 8).
- Loosen the clamp bands (to avoid sizing of high-grade steel nuts and bolts, if necessary apply some oil) (Fig. 9).

On the polished high-grade steel versions (DB, DH) unscrew the milk pipe fitting.

- Remove the pump chambers.
- Loosen the outer diaphragm plate and take it off with the diaphragm (Fig. 10).

On plastic pumps turn on the plastic cap first (from DL25).

- With compound diaphragms, the diaphragm is unscrewed by hand directly out of the plunger.
- Pull the piston rod with the second diaphragm out of the central block and disassemble the second diaphragm as described before (Fig. 11).

5.3.3 Replacement of the PTFE diaphragm

Proceed as follows to replace PTFE diaphragms:

- Pumps DL 40, 50 and 80 with PTFE diaphragms have internal diaphragm plates with bolted on shims to reduce and displace the stroke. For later changeover to PTFE diaphragm the corresponding plates must be used (Fig. 13).
- PTFE diaphragms are generally delivered with a EPDM back diaphragm. This must be mounted on the air side.
- Assembly of the pump chamber: Assembly of diaphragm, fixation by fastening the outer diaphragm plate acc. to chapter 9.4 "Tightening torques". The pump chambers must generally be assembled with the diaphragm in suction position (Press diaphragm plate into air chamber) (Fig. 15). Fasten clamp band or mounting flange. Assemble the second diaphragm in the same way. The flange face of the pump housing must be in line (Fig. 16).
- Assembly of PTFE valve seats:
PTFE valve seats (except series PM and DL15-FA/SA) are generally delivered with 2 O-rings. In order to guarantee leak tightness of the pump these O-rings must be replaced after each disassembly of the inlet and outlet ports.

Valve seats for series PM (only one O-ring or no O-ring) must be completely replaced after each disassembly of the ports.

DEPA® Air Operated Diaphragm Pumps

On plastic pumps from DL25 the O-rings in the outer diaphragm plate must be replaced after each disassembly.

- Assemble new valve balls.
- Tighten the fastening screws for suction and pressure ports with the correct torque.
- Pumps of series DH-PT/-TL are generally equipped with DEPA E4® compound diaphragms. Installation of the diaphragm takes place by means of indexing disc and set screw, without the diaphragm plate: After the set screw is threaded, the diaphragm is to be screwed onto the plunger and tightened by hand.

5.3.4 Replacement of the internal control valve

- Procedure as described under 5.3.1.
- Unscrew the air chambers from the central block (only on metal pumps, exception: DB diaphragm pumps, DH) (Fig. 12).
- Press the air control valve out of the central block.
- The air control valve is replaced as a complete unit (Fig. 17).
- For assembly of plain bearing bushings and seal ring it is recommended to use the piston rod for guidance. Take care to assemble the plain bearing bushings with the slits offset to each other (Fig. 18).
- In contrast to the assembly instructions for bearing bushings of pump series DL25 - DL80, which are fitted with two bearing bushings, the procedure for pump size DL15 with kits single bearing bushing is slightly different.

The bearing bushing has two grooves to take up the outer O-rings. In order to prevent the O-rings being damaged by

the recess in the bore the O-rings must not be pushed past the recess. For this purpose an O-ring is pushed over the bushing, the bushing is then inserted into the bore with the side without O-ring and pressed in until the groove becomes visible on the opposite side. Now the second O-ring is placed into the groove and the complete bushing is pressed flush into the bore.

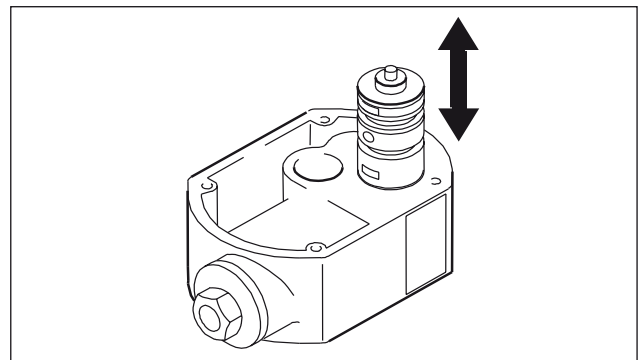

Fig. 17: Assembly of internal control valve

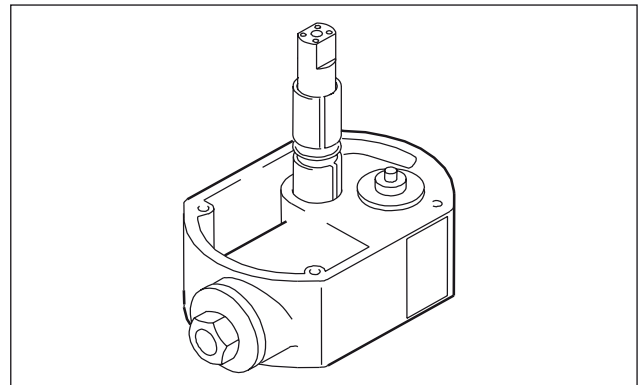

Fig. 18: Assembly of piston rod

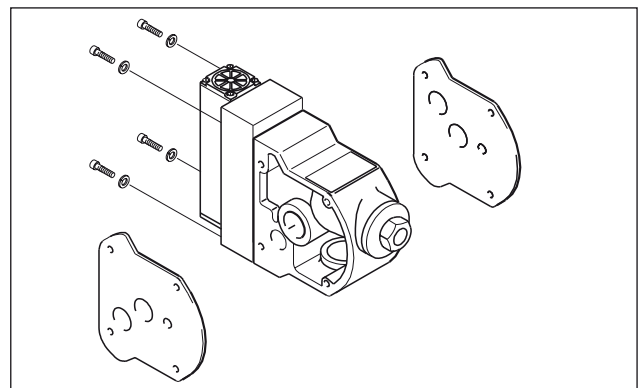

Fig. 19: Assembly of external control valve

The piston rod is only delivered completely assembled with shell and O-rings.

Replacement of the shell rings is not possible for technical reasons.

5.3.5 Replacement of the external Q-control valve

- Loosen four fastening screws on the control block. Now you can pull out the complete control valve with pilot control. This is also possible without disassembling the pump (Fig. 19).

5.4 Assembling the pump

The arrangement of parts can be seen in the exploded view.

- Assemble the gasket so that the air supply bore remains open (applies also for assembly of the air chambers).
- Check air filter and muffler for clogging, replace if necessary.

5.4.1 Assembling new clamp bands

- Assemble the new clamp bands and pre-tension these with the clamping bolts.
- Knock the clamp bands lightly with a plastic hammer onto the pump chamber for easier settling.
- Once the clamp bands have settled tighten the clamping bolts.



Danger!
Retighten the clamp bands after 5 operating hours.

6.0 Troubleshooting

Fault	Possible cause	Remedy
Pump running, no delivery	Pump draws in air Suction valve closed Suction capacity exceeded Valve ball and seat on suction side worn	Seal the suction line Open valves Change the arrangement Replace seats and balls
Insufficient pumping capacity	Muffler clogged Air inlet filter clogged Insufficient air supply Pipelines blocked Viscosity too high	Clean or renew Clean or renew Check supply line Clean Change conditions
Pump slows down, stops, restarts	Icing of the control valve	Use dry air Supply the air with anti-freeze Use a heavy-duty muffler
Reduced flow, stronger pulsation	Valve ball on suction side blocked	Ensure movability of valve ball
Product from muffler	Diaphragm cracked	Replace diaphragm
Air in product	Diaphragm cracked	Replace diaphragm
After filling the line pump standstill	Air pressure too low Too high viscosity Viscosity too high	Increase air pressure

DEPA® Air Operated Diaphragm Pumps

Fault	Possible cause	Remedy
Pump does not work despite air supply	Muffler clogged	Clean or renew
	Air inlet filter clogged	Clean or renew
	Valve balls sticking to valve seat	Loosen, use PTFE balls instead
Valve balls deformed	Chemical attack Mechanical attack	Change material Change material
Pump leaking at the clamp band	Clamp band cracked	Replace
	Diaphragm not centred during assembly	Assemble again
PTFE diaphragm cracked a after short time	Large solids in product	Install a filter
	Compressed air opened with a shock	Install a slow start valve
Insufficient suction head	Valve ball and seat leaking	Replace
	Pump completely dry	Fill suction line
Pump very loud, crackling noise	Control valve worn	Replace
	Excessive feed on the suction side	Install heavier valve balls Throttling of suction line
Piston rod hard moving	Compressed air too dry (Instrument air)	Lubricate the air
	Temperature too high	Cool down
	Compressed air dirty	Install a filter
	Piston rod run in	Replace

7.0 Active pulsation damper

7.1 Function

The active pulsation dampers are designed for in-line installation. The pressure peaks of the flowing product raise the diaphragm and compromise the air cushion in the air chamber.

When the displacement pressure in the pipeline drops, the diaphragm is pressed down by the compressed air cushion which keeps the pressure in the pipeline virtually constant.

The pressure in the air chamber automatically adjusts as a result of the internal air control if the pressure in the pipeline is increased due to system conditions.

Any extra pressure needed is supplied by the air port; excess pressure escapes through the muffler.

We recommend installing the pulsation damper directly on the discharge manifold of the pump.

7.2 Recommended installation schematic

Pulsation dampers can be mounted in any position, as long as there are not intentions to install diaphragm breakage monitoring.

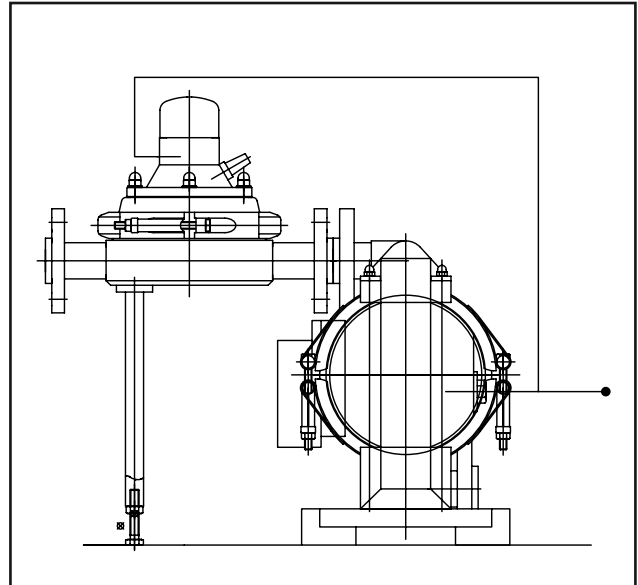

Sketch 1

The air supply connection must always be independent from the pump, so that the air pressure for the pulsation damper can be adjusted separately.

One must always make sure that the weight of the pulsation damper is supported as shown in sketch 1 and any load is taken off the pump connection.

If the pulsation damper is directly mounted to the pressure socket of the pump, a flexible connection (e.g. compensator) should be considered to connect to the onwards pipeline.

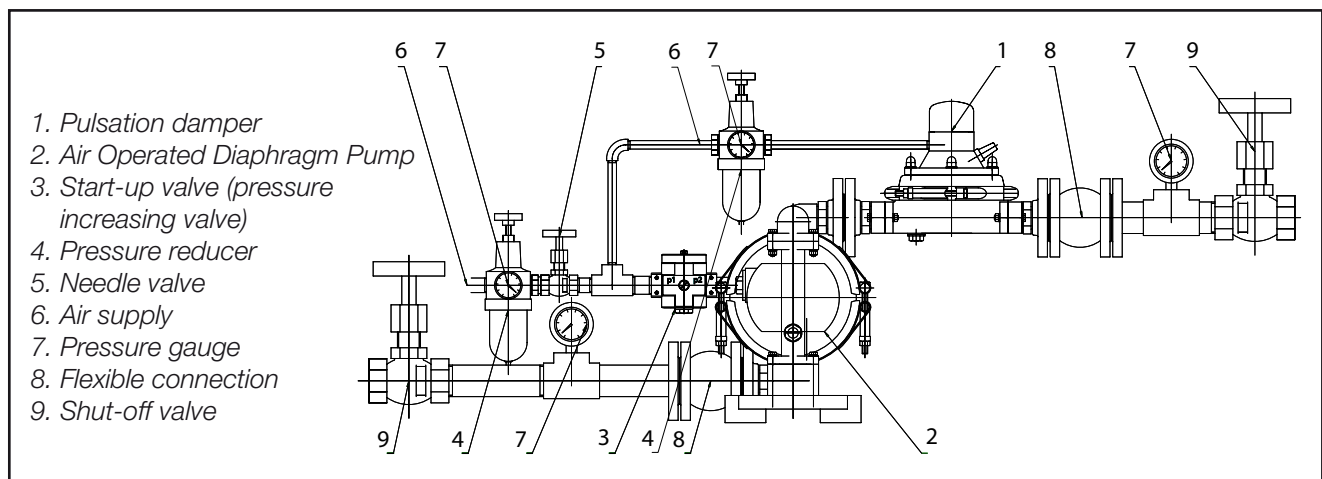

Sketch 2

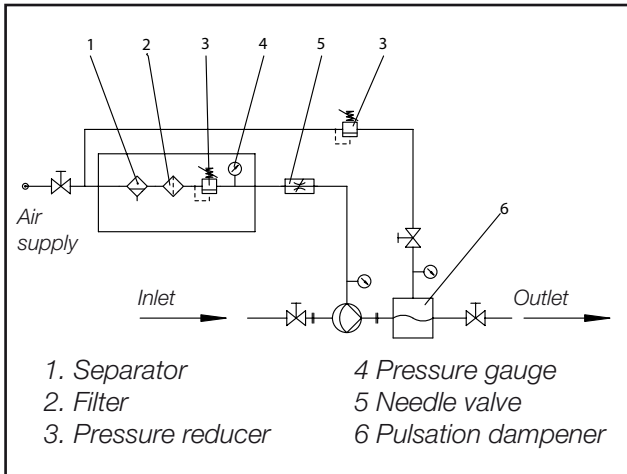

Sketch 3

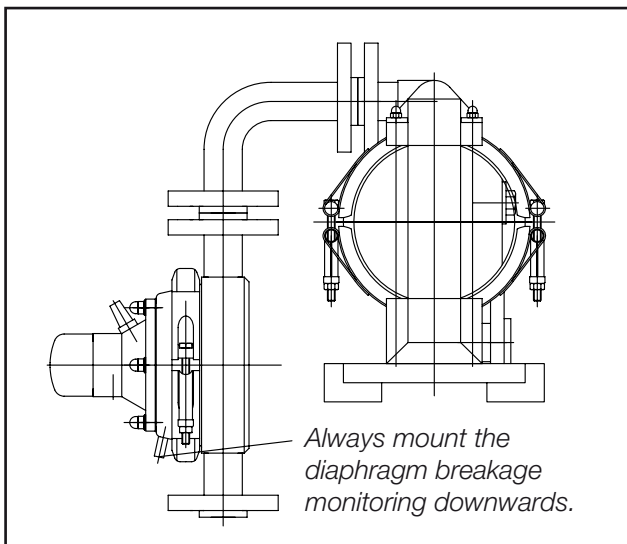

Sketch 4

7.3 Pulsation damper with diaphragm breakage monitoring

Pulsation dampers equipped with a diaphragm monitoring system in the air chamber must not be installed horizontally, they must be vertically installed as otherwise the function of the diaphragm monitoring system is not assured (see sketch 4).

8.0 Spare Parts

8.1 Spare parts storage

Since the extent of the recommended spare parts storage depends on the period of use and the different operating conditions for the pumps, you should consult the manufacturer or an authorized dealer.

8.2 Ordering spare parts

Please state the following when ordering spare parts:

- Pump type
- Construction year and serial number
- Spare parts article number

Should subsequent material changes for different parts of the pump have taken place, this information is mandatory. The required spare parts and their article numbers can be found in the spare parts lists. These can be found under www.cranepharmaceutical.com.

Liability when using non-genuine spare parts:

The installation and/or use of non-genuine spare parts or accessories can have a negative effect on design features of the air operated diaphragm pump and thus adversely affect its operation. For damage caused by the use of non-genuine spare parts and accessories on pump, system or product all liability and warranty is excluded.

9.0 Appendix “materials and pump coding”

Series	
Standard series made of cast metal, plastic and high-grade steel, polished	DL
High grade steel, plastic flanged design	DH
Drum pump	DF
Double pump	DZ
Powder pump	DP
High pressure pump	DB
Special pump without own control valve	DJ

DL 40 - PP - E E E

Pump size			
Connections	R1/2"	DN 15	15
Connections	R1"	DN 25	25
Connections	R1 1/2"	DN 40	40
Connections	R2"	DN 50	50
Connections	R3"	DN 80	80

Max. pressure range	
All types as specified DB pumps to 21 bar	-
DB pumps to 16 bar	B
DB pumps to 13 bar	A

Material assembly groups			
Housing	Diaphragm plate	Control block	
Cast aluminium	High-grade steel	Cast aluminium	FA
Nodular cast iron***	Steel	Cast aluminium	CA
Nodular cast iron***	Steel	Cast bronze***	CX
Cast high-grade steel	High-grade steel	Cast aluminium	SA
Cast high-grade steel***	High-grade steel	Cast aluminium	SF
Cast high-grade steel***	High-grade steel	Cast bronze	SX
Cast high-grade steel***	High-grade steel	High-grade steel	SS
High grade steel polished 1.4301 (AISI/BS 304)	High grade steel polished 1.4301 (AISI/BS 304)	Cast aluminium nickel-plated	SL
High grade steel polished AISI/BS 316L (1.4404)	High grade steel polished AISI/BS 316L (1.4404)	Cast aluminium nickel -plated	UL/ SU/ UE
PP*	PP*	PP*	PP
PP injection moulded****	PP*	PP*	PM
PP* electr. conductive	PP* electr. conductive	PP* electr. conductive	PL
PTFE**	PTFE**	PP*	PT
PTFE** electr. conductive	PTFE** electr. conductive	PP* electr. conductive	TL

Interior equipment	Diaphragm	Seats	Balls
NRS	B	B	B***
NBR (Buna N®)	N	N	N***
EPDM (Nordel®)	E	E	E***
EPDM (grey)	G	G	G***
FKM (Viton®)	F	F	-
PTFE (Teflon®)**	T	T	T
EPDM grey for series DH	U	-	-
PTFE ** for series DH	P	-	-
DEPA E4® compound diaphragms	Z	-	-
High-grade steel	-	R	R
High-grade steel DB	-	H	R***
NBR, steel core***	-	-	Y***
EPDM, steel core***	-	-	W***
EPDM, grau with steel core***	-	-	X***
PTFE**, steel core***	-	-	Z***
NRS, steel core***	-	-	V***
Hyrel®	H	-	-

* Polypropylene solid
 ** Polytetrafluoroethylene not for DL 15
 *** not for DL 15
 **** PP-injection molding, only size 15/25/40

9.1 Appendix „pump weights in kg“

Pump size	FA	CA	CX	SA/SF	SX	PM	PP/PL	PT/TL	DL-SL/SU/UE	DH-UE	DB
15	3,5	-	-	4,8	-	6	5	8	9	10	-
25	9	13	16	14	17	8,4	10	14	21	27	35
40	14	23	24	29	31	13	17	22	30	33	49
50	29	50	51	51	53	-	37	61	57	73	90
80	58	100	105	119	125	-	75	-	94	-	-

9.2 Devices for use in explosion endangered environments

Materials				
Model type	Housing	Diaphragm	Control block	Diaphragm plate
DL, DF, DZ, DJ, DP	FA/CA/SA	EPDM-electr. conductive PTFE, PTFE/EPDM compound diaphragm NBR-electr. conductive	Aluminium	High-grade steel
DL/DH	PL / TL	EPDM-electr. conductive PTFE, PTFE/EPDM compound diaphragm NBR-electr. conductive	PP-electr. conductive	PL / TL
PD	PL / TL SX / CX SS / CS	EPDM-electr. conductive PTFE, PTFE/EPDM compound diaphragm NBR-electr. conductive	High-grade steel	PL / TL High-grade steel

9.2.1 Example

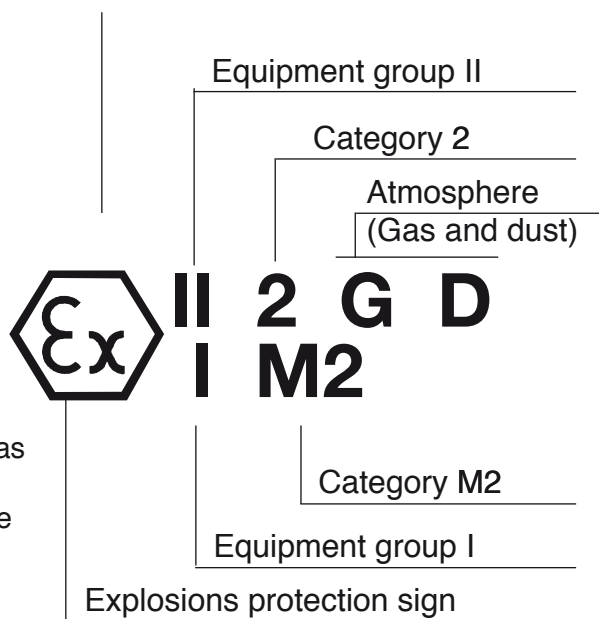

9.2.2 Surface temperature

During intended use the pump will not get hot and thus has almost ambient or product temperature. All moving parts are cooled by the expanding drive air (gas). However, due to the high medium temperature the surface of the pump may also reach the temperature of the medium.

9.2.3 Devices for use in explosion endangered areas
Supplement for type approved pumps of category 1



II 1 G IIA Tx

Pumps type: DL..-SS-...
for sizes: 50 and 80
Diaphragm materials: PTFE with EPDM electrically conductive back diaphragm; EPDM electrically conductive, NBR electrically conductive, DEPA E⁴® compound diaphragm



II 1 G IIB Tx

Pumps type: DL..-SS-...
for sizes: 15, 25 and 40
Diaphragm materials: PTFE with EPDM electrically conductive back diaphragm; EPDM electrically conductive, NBR electrically conductive, DEPA E⁴® compound diaphragm

IIA and IIB:

Explosion group

Tx:

No temperature increase by operation of the pump. The temperature is solely determined by the environment or the product.

DEPA® Air Operated Diaphragm Pumps

The waste air must be collected and discharged from the potentially explosive area (e.g. by means of an electrically conductive hose between pump and silencer).

9.3 Classification of pump groups I and II

Pump groups (Appendix I of EC-directive 94/9/EC)							
Group I (Mines, mine gases and dust)		Group II (other explosive mixed gases/dust)					
Category M		Category 1		Category 2		Category 3	
1 (Zone 0/20)	2 (Zone 1/21)	G (Gas) (Zone 0)	D (Dust) (Zone 20)	G (Gas) (Zone 1)	D (Dust) (Zone 21)	G (Gas) (Zone 2)	D (Dust) (Zone 22)
for equipment providing very high protection in case of danger caused by an explosive atmosphere	for equipment providing very high protection in case of possible danger caused by an explosive atmosphere	for equipment providing extremely high protection when used in areas in which an explosive atmosphere may arise		for equipment providing high protection when used in areas in which an explosive atmosphere may arise		for equipment providing normal protection when used in areas in which an explosive atmosphere may arise	

Pumps and pump units intended for use in potentially explosion endangered atmospheres are normally classified in group II, category 2. The user is solely responsible for classifying the group and the category.

9.4 Tightening torques series L, size 15 (design until end of 2007)

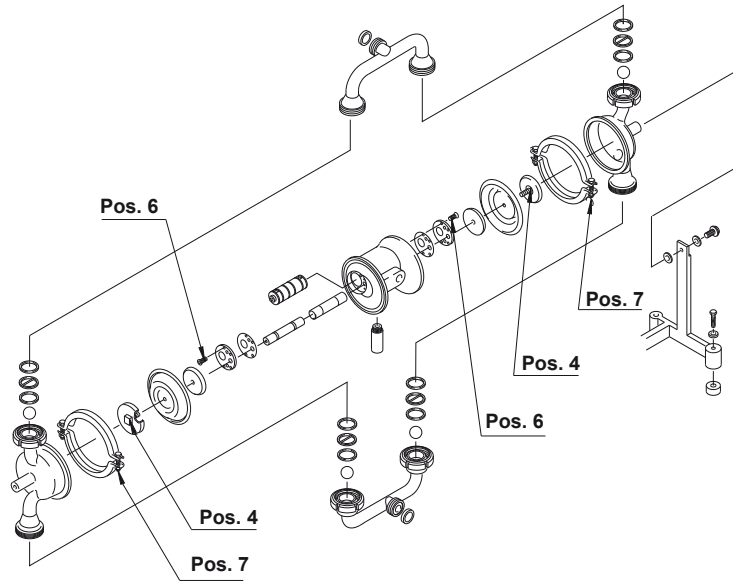

Pump size	Piston Pos. 4	Centre block cover Pos.6	Clamp band Pos. 7
DL15-L	6 Nm	2,5 Nm	max. 23 Nm

Tightening torques series L, size 25-80

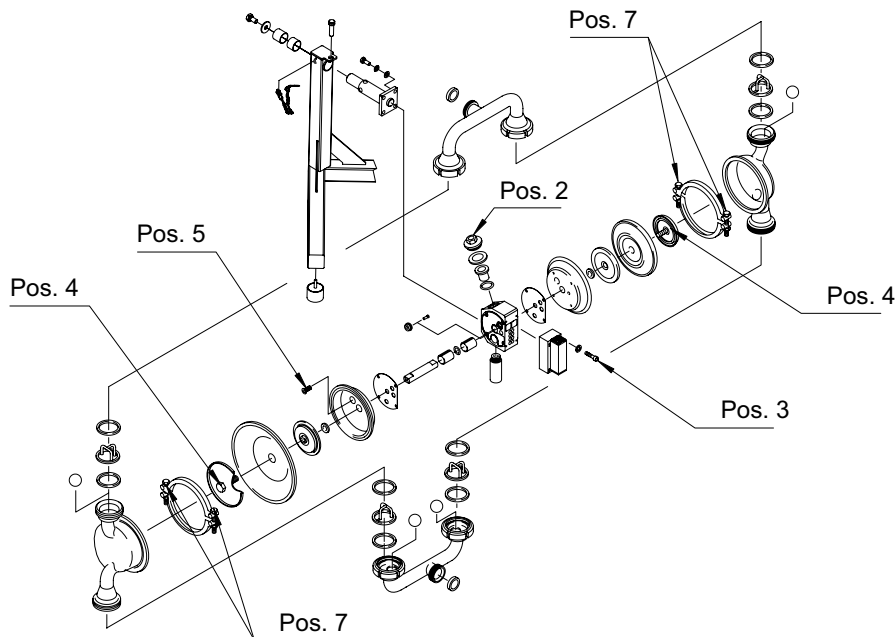

Pump size	Air inlet Pos. 2	Air valve Pos. 3	Piston Pos.4	Air chamber Pos. 5	Clamp band Pos. 7
DL25-L	50 Nm	8 Nm	-	20 Nm	max. 23 Nm
DL40-L	50 Nm	8 Nm	90 Nm	20 Nm	max. 23 Nm
DL50-L	85 Nm	8 Nm	150 Nm	39 Nm	max. 23 Nm
DL80-L	85 Nm	8 Nm	150 Nm	39 Nm	max. 23 Nm

DEPA® Air Operated Diaphragm Pumps

Tightening torques series DH-UE, size 25-50

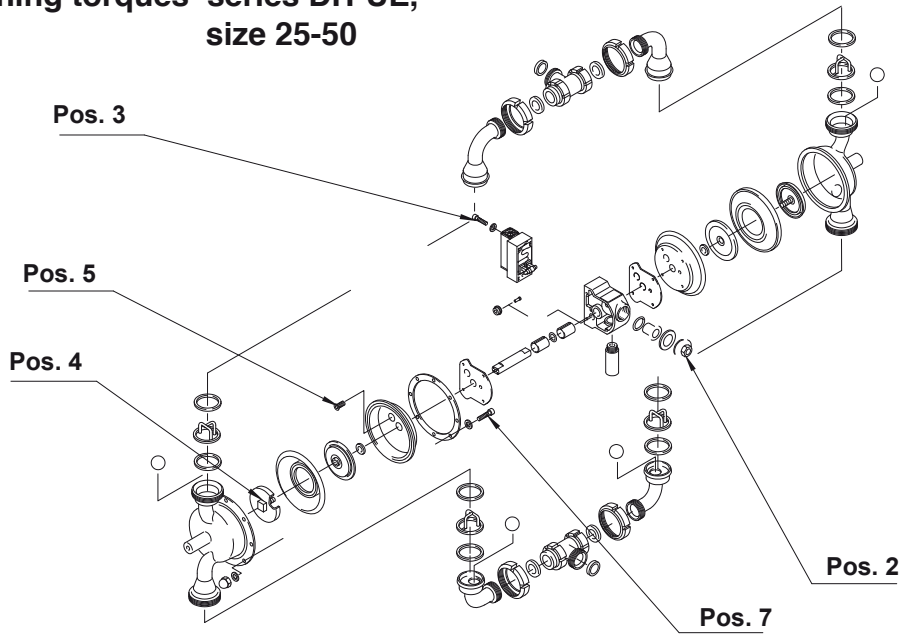

Pump size	Air inlet Pos. 2	Air valve Pos. 3	Piston Pos. 4	Air chamber Pos. 5	Pump chamber / Flange, Pos. 7
DH25-UE	50 Nm	8 Nm	90 Nm	20 Nm	25 Nm
DH40-UE	50 Nm	8 Nm	90 Nm	20 Nm	25 Nm
DH50-UE	85 Nm	8 Nm	150 Nm	39 Nm	49 Nm

Tightening torques series SF, size 25-50

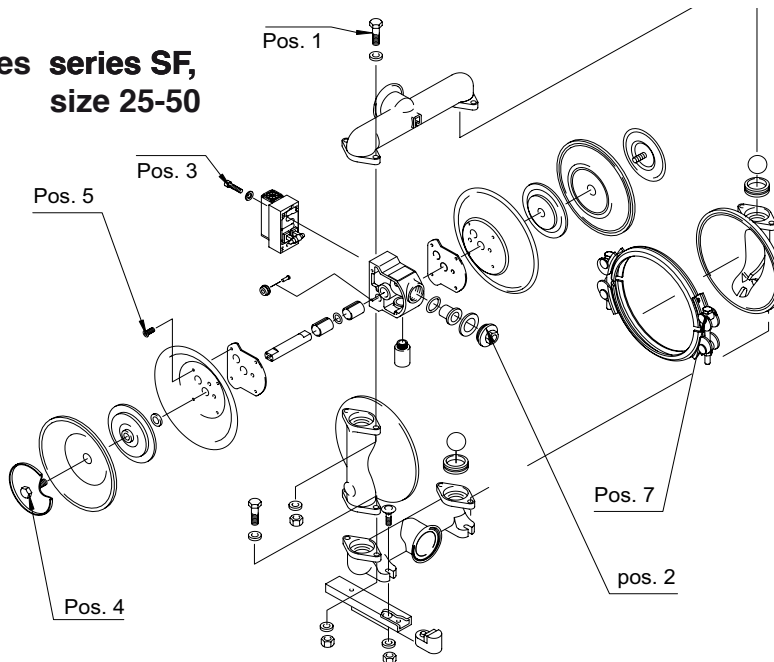

Pump size	Suction / Discharge manifold, Pos. 1	Air inlet Pos. 2	Air valve Pos. 3	Piston Pos. 4	Air chamber Pos. 5	Clamp band Pos. 7
DL25-SF	10 Nm	50 Nm	8 Nm	70 Nm	20 Nm	max. 23 Nm
DL40-SF	25 Nm	50 Nm	8 Nm	90 Nm	20 Nm	max. 23 Nm
DL50-SF	49 Nm	85 Nm	8 Nm	150 Nm	39 Nm	max. 23 Nm

Tightening torques series M, size 15

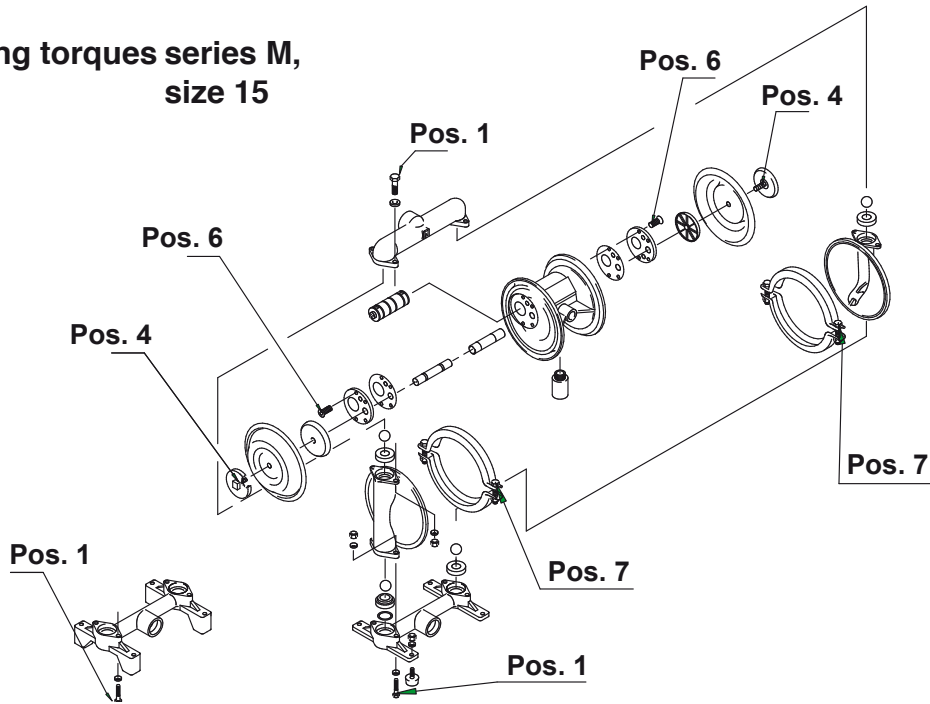

Pump size	Suction / Discharge manifold, Pos. 1	Piston Pos. 4	Centre block cover Pos. 6	Clamp band Pos. 7
DL15-M	7 Nm	6 Nm	3 Nm	max. 23 Nm

Tightening torques series M, size 25-80

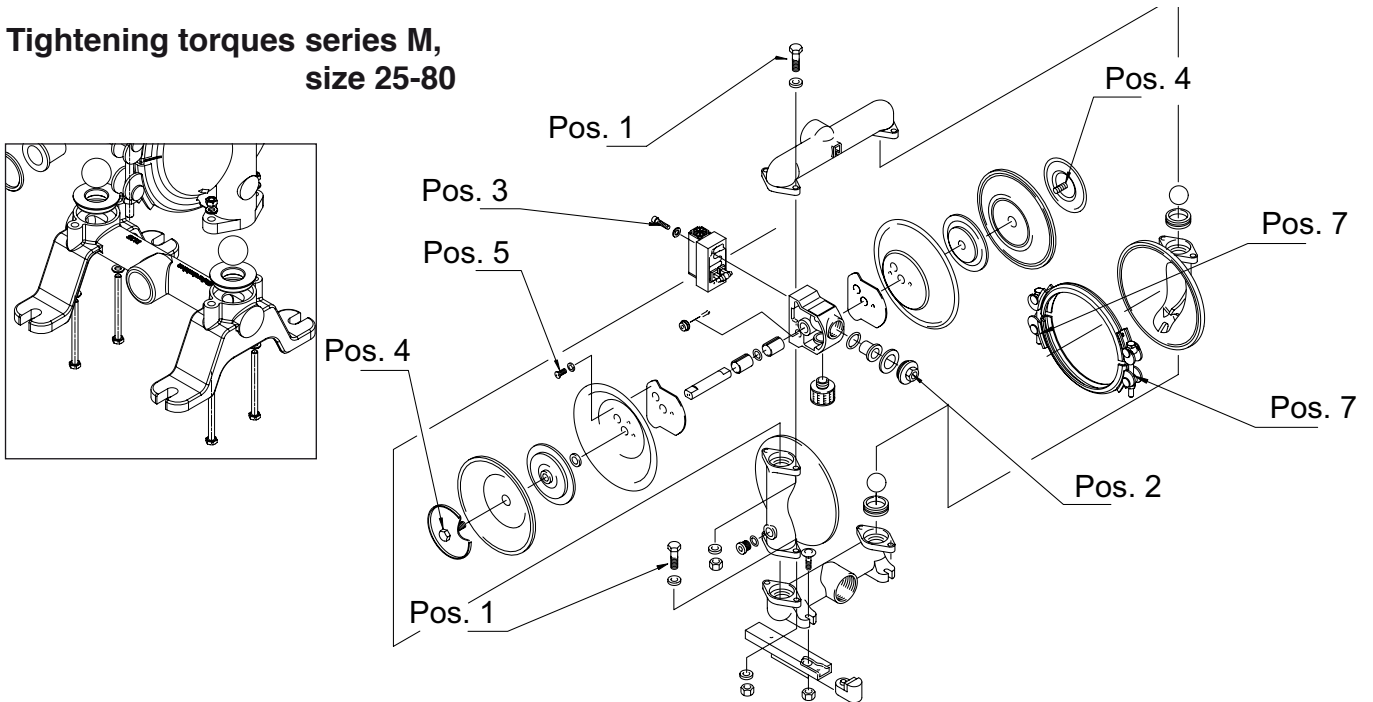

Pump size	Suction / Discharge manifold, Pos. 1	Air inlet Pos. 2	Air valve Pos. 3	Piston Pos. 4	Air chamber Pos. 5	Clamp band Pos. 7
DL25-M	25 Nm	50 Nm	8 Nm	70 Nm	20 Nm	max. 23 Nm
DL40-M	25 Nm	50 Nm	8 Nm	90 Nm	20 Nm	max. 23 Nm
DL50-M	49 Nm	85 Nm	8 Nm	150 Nm	39 Nm	max. 23 Nm
DL80-M	49 Nm	85 Nm	8 Nm	150 Nm	39 Nm	max. 23 Nm

DEPA® Air Operated Diaphragm Pumps

Tightening torques series P, size 15-80

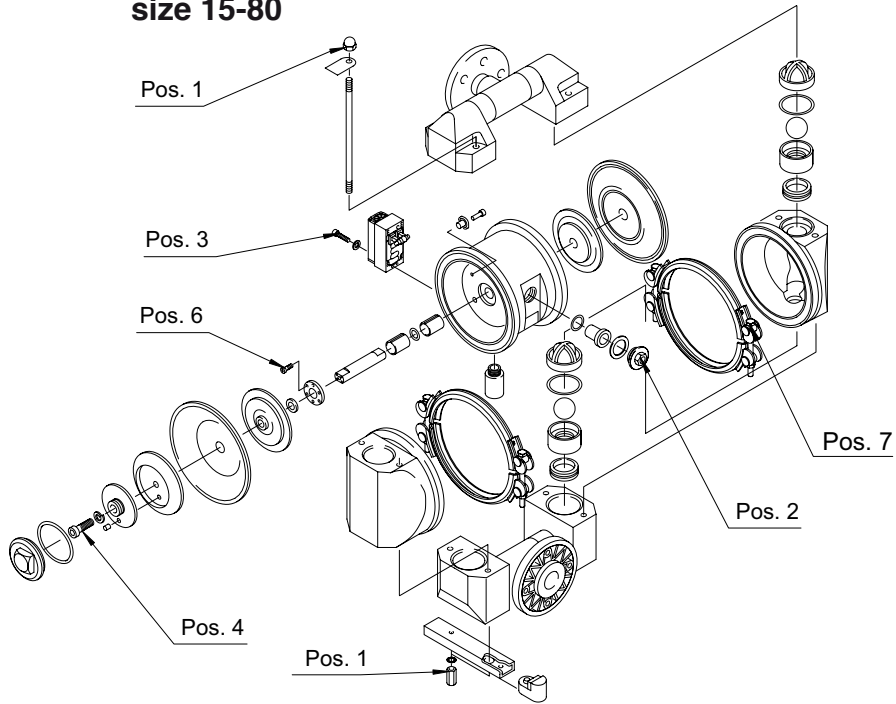

Pump size	Anchor rod Pos. 1	Air inlet Pos. 2	Air valve Pos. 3	Piston Pos. 4	Centre block cover, Pos. 6	Clamp band Pos. 7
DL15-P	10 Nm	-	-	6 Nm	2,5 Nm	7 Nm
DL25-P	10 Nm	50 Nm	8 Nm	70 Nm	2,5 Nm	8 Nm
DL40-P	25 Nm	50 Nm	8 Nm	90 Nm	2,5 Nm	10 Nm
DL50-P	49 Nm	85 Nm	8 Nm	150 Nm	5,5 Nm	12 Nm
DL80-P	49 Nm	85 Nm	8 Nm	150 Nm	5,5 Nm	15 Nm

Tightening torques series P, Typ DH,
size 50

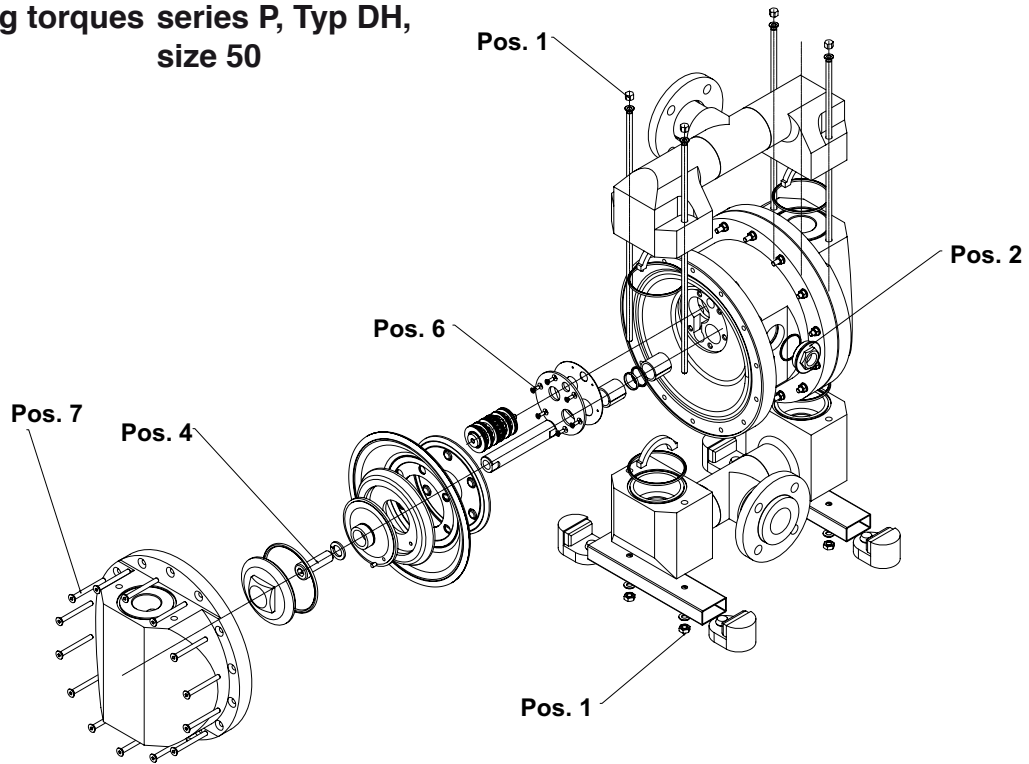

Pump size	Anchor rod Pos. 1	Air inlet Pos. 2	Air valve Pos. 3	One piece diaphragm Pos. 4	Piston Pos. 4	Centre block cover Pos. 6	Pump chamber/ Centre block Pos. 7
DH50-P	35 Nm	85 Nm	8 Nm	-	150 Nm	5,5 Nm	12 Nm

DEPA® Air Operated Diaphragm Pumps

Tightening torques series P, type DH-PT/-TL size 15-40

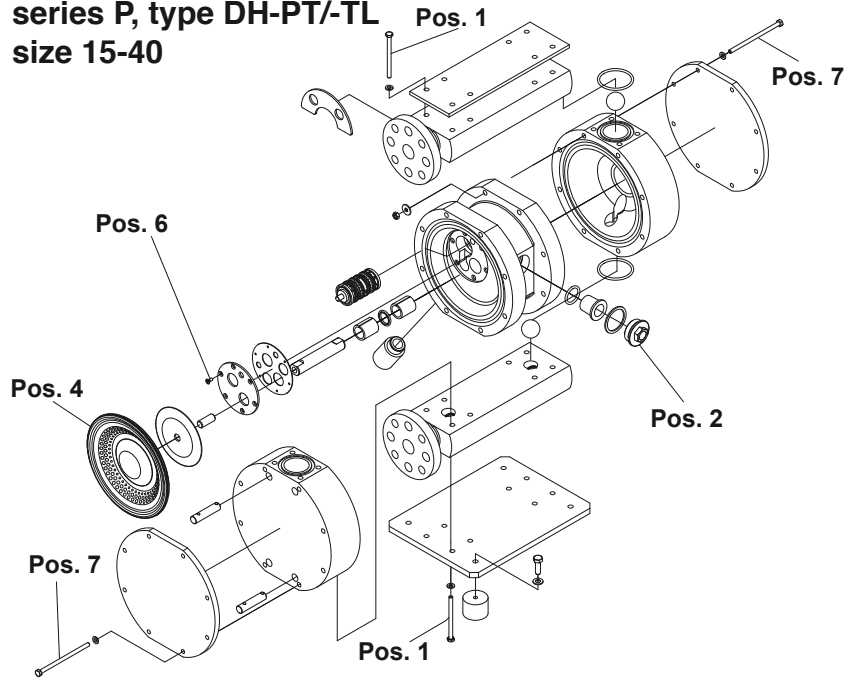

Pump size	Manifold / Pump chamber Pos. 1	Air inlet Pos. 2	Diaphragm Pos. 4	Centre block cover Pos. 6	Pump chamber / Centre block Pos. 7
DH15-PT/TL	3 Nm	50 Nm	1 Nm	2,5 Nm	6 Nm
DH25-PT/TL	5 Nm	50 Nm	1 Nm	2,5 Nm	6 Nm
DH40-PT/TL	5 Nm	50 Nm	1 Nm	2,5 Nm	6 Nm

Tightening torques series P, type PM, size 15-40

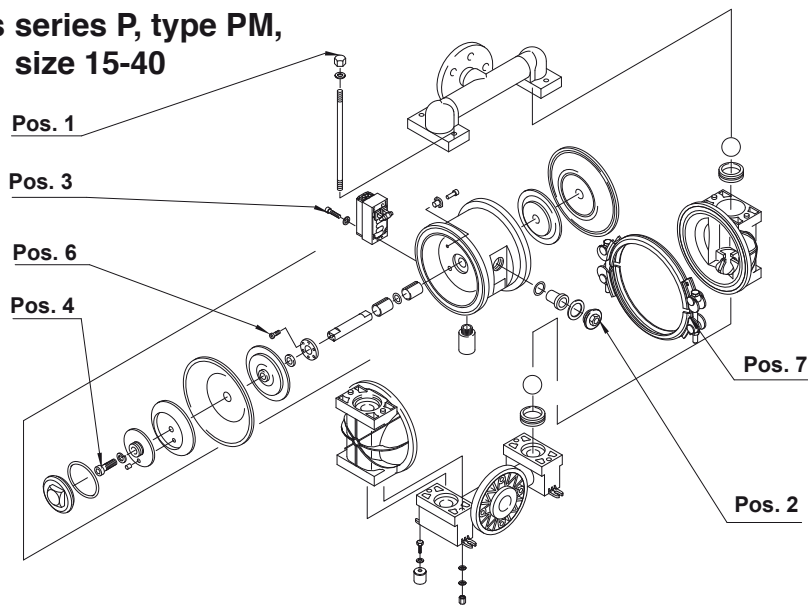

Pump size	Anchor rod Pos. 1	Air inlet Pos. 2	Air valve Pos. 3	Piston Pos. 4	Centre block cover, Pos. 6	Clamp band Pos. 7
DL15-PM	8 Nm	-	-	6 Nm	2,5 Nm	7 Nm
DL25-PM	10 Nm	50 Nm	8 Nm	70 Nm	2,5 Nm	8 Nm
DL40-PM	25 Nm	50 Nm	8 Nm	90 Nm	2,5 Nm	10 Nm



Declaration of harmlessness

Please attach to the equipment delivery or send as letter (if urgent by fax).

Crane Process Flow Technologies GmbH
Heerdter Lohweg 63-71
D-40549 Düsseldorf
Service Department
Fax: +49 211 / 5956-139

We want to protect our employees against any risks arising from contaminated equipment, as far as this is possible. We therefore ask you for your kind understanding, that we will only be able to carry out any inspections/repairs, after we have received this fully filled in and signed declaration.

Concerning the return dated..... / Delivery note no.:.....
.....

Pump type:.....

With my signature I declare:

- that the returned pump has been thoroughly cleaned and decontaminated before shipment.
- that the returned pump will not pose any dangers caused by bacteriological, virological, chemical or radioactive contamination.
- that I am authorized to issue such declarations for the company concerned.

For the repair service we kindly ask you to supply us with the following additional information:

Detected defect:

.....

Media used:

.....

Company stamp

Name:

Position:

Date, signature:



This is the translation of the original operating and installation instructions for DEPA Air Operated Diaphragm Pumps.

For the original version in German, please refer to www.cranepharmaceutical.com

Crane Process Flow Technologies GmbH

P.O.Box 11 12 40, D-40512 Düsseldorf
Heerdter Lohweg 63-71, D-40549 Düsseldorf
Phone +49 211 5956-0
Fax +49 211 5956-111
info.germany@craneflow.com
www.cranechempharma.com

We reserve the right to change all technical information.

